



**UNIFASTENER**  
**BOLT INDUSTRIES**  
MAKING YOUR LIFE SIMPLE

+971 50 770 7528   
+971 55 5610 468 

 New Industrial Area,  
Umm Al Quwain - U.A.E

 [unifastenerind@gmail.com](mailto:unifastenerind@gmail.com)  
[www.unifastenerind.com](http://www.unifastenerind.com)

# ABOUT US

UNIFASTENER Bolt Industries LLC, an ISO 9001:2015 (QMS) CERTIFIED COMPANY is an Industrial fasteners manufacturer with production facilities in New Industrial Area, Umm Al Quwain In UAE. The company is promoted & managed by experienced management who has a vast experience of 30 years in manufacturing & trading of steel products and Fasteners in UAE. Early beginnings started with import & supply of vast range of Fasteners to Local Construction, MEP & Manufacturing sector which with experience gained helped to establish their own manufacturing unit to provide tailor made fasteners to these industries across GCC, Middle East & African countries.

With the proud vision of UAE to excel in manufacturing sector as well, We have proudly invested in Raw material stocks, Modern Machinery & Experienced workforce to meet the needs of Oil & Gas industries, Construction & MEP sector thru our manufacturing & supply with Lower turnaround times & fast deliveries.

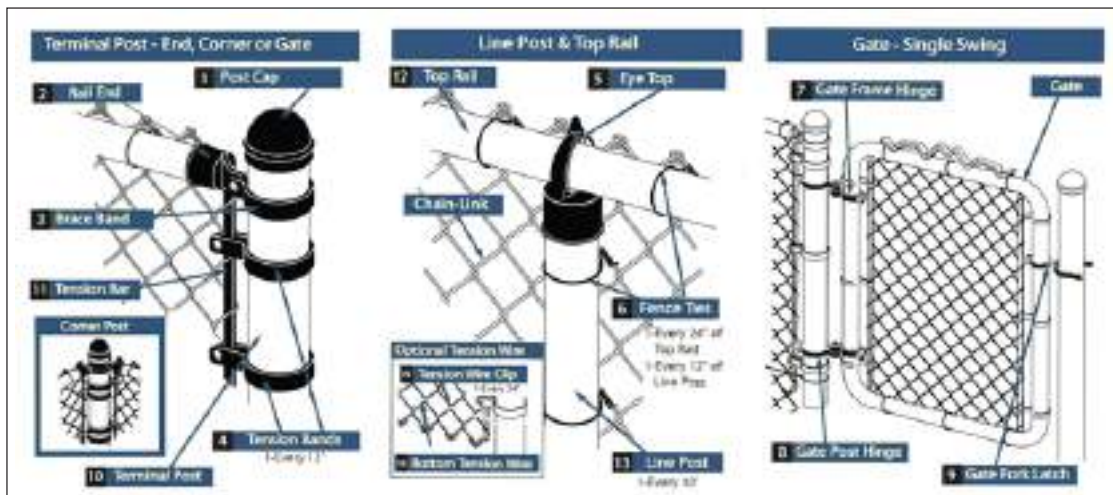

## Double Clamp

- Material: pressed steel.
- Surface treatment: hot-dip galvanized or PVC-coated.
- Color: match the color coating of the fabric.
- Minimum thickness: 14 gauge.
- Range: 1/2" thru 6".



## Brace Band

- Material: pressed steel.
- Surface treatment: hot-dip galvanized or PVC-coated.
- Color: match the color coating of the fabric.
- Minimum thickness: 14 gauge.
- Minimum width: 3/4".



## Tension Clamp

- Material: pressed steel.
- Surface treatment: hot-dip galvanized or PVC-coated.
- Color: match the color coating of the fabric.
- Minimum thickness: 14 gauge.
- Minimum width: 3/4"



INCHES (in)	MILLIMETER (mm)
1-3/8"	36
1-5/8"	42
1-7/8"	48
2-3/8"	60
2-7/8"	76
3-1/2"	89
4"	105
4-1/2"	115

## Rail End (One Whole Round)

Surface Treatment:- WZP, HOT DIP GALVANIZED and PVC POWDER COATED  
 Color:- Matching in any Color of your Choice with the Fabric/ Mesh- Green/ Black



## Rail End (Half Moon)

Surface Treatment:- WZP, HOT DIP GALVANIZED and PVC POWDER COATED  
 Color:- Matching in any Color of your Choice with the Fabric/ Mesh- Green/ Black



## Post Cap

Surface Treatment:- WZP, HOT DIP GALVANIZED and PVC POWDER COATED  
 Color:- Matching in any Color of your Choice with the Fabric/ Mesh- Green/ Black



INCHES (in)	MILLIMETER (mm)
1-3/8"	36
1-5/8"	42
1-7/8"	48
2-3/8"	60
2-7/8"	76
3-1/2"	89
4"	105
4-1/2"	115

## Barb Arm (45 Deg. – Single)

- Material:- Pressed steel
- FINISH:- HDG/ GREEN PC.
- Thickness: 1.60- 2.50 MM
- Size:- 1-5/8" x 1-5/8"(42X42)  
2-1/2" x 1-5/8" (60 x 42)



## Barb Y Arm (Double V Type)

- Material:- Pressed steel
- FINISH:- HDG/ GREEN PC.
- Thickness: 1.60- 2.50 MM
- Size:- 1-5/8" x 1-5/8"(42X42)  
2-1/2" x 1-5/8" (60 x 42)



## Loop Cap

- Material:- Pressed steel
- FINISH:- HDG/ GREEN PC.
- Thickness: 1.60- 2.50 MM
- Size:- 42x42MM, 48x42MM



## Line Rail Clamp

- Material:- Pressed steel
- FINISH:- HDG/ GREEN PC.
- Thickness: 1.60- 2.50 MM
- Size: 1-5/8" x 1-5/8"(42X42)  
1-7/8" x 1-5/8" (48x 42)



## End Rail Clamp

- Material:- Pressed steel
- FINISH:- HDG/ GREEN PC.
- Thickness: 1.60- 2.50 MM
- Size: 1-5/8" x 1-5/8"(42X42)  
1-7/8" x 1-5/8" (48x 42)



## W-Saddle Clamp

- Material:- Pressed steel
- FINISH:- HDG/ GREEN PC.
- Thickness: 1.60- 2.50 MM
- Size: 25x25MM, 33x33MM  
42x42MM



## Male/Female Hinge

- Material:- Pressed steel
- FINISH:- HDG/ GREEN PC.
- Thickness: 2.00- 3.00 MM
- **Size: 1-5/8" x 1-5/8" (42X42)**  
**1-7/8" x 1-5/8" (48 x 42)**



## Wire Strainer

- Material:- Pressed steel
- FINISH:- HDG/ GREEN PC
- Thickness: 1.60- 2.00 MM



## Ratchet Winder

- Material:- Pressed steel
- FINISH:- HDG/ GREEN PC.
- Thickness: 1.60- 2.00 MM
- **One standard size**



## Short Winder

- Material:- Pressed steel
- FINISH:- HDG/ GREEN PC.
- Thickness: 2.00- 3.00 MM
- **Size:- 24 X 3MM X 4"**



## Loop Nut & Eye Bolt

- Material:- Casting& welded loop nut
- FINISH:- HDG/ GREEN PC.
- Dia/Lgth. M8-M10, Lgth: 100-270mm



## Truss Rod Tightener

- Material:- Casting& welded loop nut
- FINISH:- HDG/ GREEN PC.
- Size:- 6 - 8mm



## Fencing Coupler

- Material:- Pressed steel
- Finish:- Galvanised/ HDG
- Thickness:- 1.60mm-2.50mm
- Type:- with & w/o Wire gauge

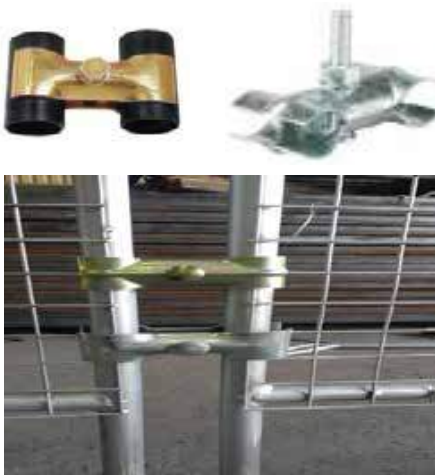

## Scaffolding Coupler

- Material:- Pressed steel
- Finish:- Yellow zinc plated
- Rtype:- Fixed & swivel rotating
- Weight:- 500-580gm
- Size:- 48x48mm, 60x48mm



## Putlog Coupler

- Material:- Pressed steel
- Finish:- WZP / YZP Plated
- Weight:- 580-600gm



## Sleeve Coupler

- Material:- Pressed steel
- Finish:- Galvanised/ HDG



## Joint Pin With Bolt

- Material:- Pressed steel
- Finish:- Galvanised/ HDG



## PVC Hoarding Clamp

- Material:- Pressed steel
- Finish:- Galvanised/ HDG



# FENCING ACCESSORIES



# FENCING ACCESSORIES



# FENCING ACCESSORIES



LIFTING EYE BOLT NUT



GI CHAIN - 3 TO 12MM



BOW SHACKLES



CARRIAGE BOLT NUT



ANTI THEFT BOLT & NUT



L-CORNER



POLE MESH CLIP



PVC CLIP FOR WELD MESH



WIRE ROPE CLIPS



GALVANIZED WIRE ROPES



SLEEVE PIPES



FENCING POLE CLAMPS



T BOLT HOSE CLIP



FIXING SCREWS - DIFFERENT HEADS - GI & SS - 304 / 316



# UNIFASTENER BOLT INDUSTRIES

MAKING YOUR LIFE SIMPLE



## Our Distribution Partner:

### FAIRDEAL HARDWARE TRADING LLC

 +971 4 228 7267  
+971 55 752 0381

 Baniyas Square  
Deira, Dubai - U.A.E

 [fht@eim.ae](mailto:fht@eim.ae)

## CONTACT US



 +971 50 770 7528  
+971 55 5610 468

 New Industrial Area,  
Umm Al Quwain - U.A.E

 [unifastenerind@gmail.com](mailto:unifastenerind@gmail.com)  
[www.unifastenerind.com](http://www.unifastenerind.com)

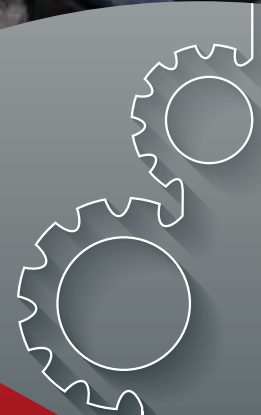

 050 770 7528 / 054 321 8371 

[info@unifastenerind.com](mailto:info@unifastenerind.com)

P.O.BOX: 42257  
Shed #5 & 6, New Industrial Area,  
Umm Dearaa, Umm Al Quwain, U.A.E

[www.unifastenerind.com](http://www.unifastenerind.com)



## About Us

Unifastener Industries LLC, an ISO 9001:2015 (QMS) CERTIFIED COMPANY is an Industrial fasteners manufacturer with production facilities in NEW INDL AREA, Umm Al Quwain In UAE. The company is promoted & managed by experienced management who has a vast experience of 30 years in manufacturing & trading of steel products and Fasteners in UAE. Early beginnings started with import & supply of vast range of Fasteners to Local Construction, MEP & Manufacturing sector which with experience gained helped to establish their own manufacturing unit to provide tailor made fasteners to these industries across GCC, Middle East & African countries. With the proud vision of UAE to excel in manufacturing sector as well, We have proudly invested in Raw material stocks, Modern Machinery & Experienced workforce to meet the needs of Oil & Gas industries, Construction & MEP sector thru our manufacturing & supply with Lower turnaround times & fast deliveries.

### Our product range available in a vast range of sizes consist of:-

- FOUNDATION ANCHOR BOLTS
- STUD BOLTS
- THREADED RODS
- BENT BOLTS & U BOLTS
- HEAVY CLAMP & BRACKETS

At Unifastener Industries we manufacture standard, customized & non-standard fasteners based on the requirements & Drawings provided by the customers technical team. Our experienced and well qualified staff ensures all aspects of order execution from inquiry to delivery & in between production are handled with swift response & stringent quality procedures are maintained to supply a superior product to our clients. All our Raw material is sourced from quality suppliers & orders are delivered with material Test Certificates which ensure full traceability.

We at Unifastener maintain optimal service standards, competitive prices, quality products and Punctual delivery to ensure Utmost customer satisfaction.



### CERTIFICATE OF REGISTRATION



  
 We Do Not Sell, We Certify!

This Certificate has been awarded to  
**UNIFASTENER INDUSTRIES LLC**  
 Unit Nos. 05 & 06, Plot No. 1499  
 Umm Dearaa, P.O. Box - 42257 (Dubai)  
 Umm Al Quwain, United Arab Emirates

In recognition of the organization's Management System  
 which complies with  
**ISO 9001:2015 (QMS)**

The scope of activities covered by this certificate is defined below  
**Manufacturing & Exporting of Anchor Foundation bolts, Stud Bolts,  
 Bent Bolts, Screws Nuts & similar Threaded Products, Pipe Clamps,  
 Metal Vices including Metal Forging, Pressing, Stamping,  
 Roll-forming and Metal Coating**

**SINDICATE OF INTERNATIONAL SYSTEM CERTIFICATIONS**  
 Certificate Number: SIS090621Q341  
 Date of Issue of Original Certificate: 25.06.2021  
 Date of Issue of latest certificate: 25.06.2021  
 Expiry Date: 24.06.2022  
 Re-certification Due on: 25.06.2024

Note: This certificate is valid only if produced with the continuation letter after the surveillance is carried out successfully.  
 The Organization's documentation and implementation has been reviewed and found to comply with the relevant standard rules. This certificate of Registration is based on the evaluation of the mentioned scope given above. Organization is responsible for maintaining the responsibility of the "relevant standard" rules. Any significant changes in the scope of the certification, or standards referred, above mention this certificate issued, will be an automatic certificate transfer to the Certification No. 03, address of the International Accreditation Services - 3500 Silver Street Suite 100 Brea, California 92621-1702, USA, International Accreditation Services, 3500 Silver Street Suite 100 Brea, CA 92621-1702, USA. Email us - info@iascertifications.com, info@iascertifications.com or Call - +91 99105 01306, +91 99282 51201. Web: http://www.iascertifications.com, www.iascertifications.com  
 The status of this certificate can be verified on "http://www.iascertifications.com"

  
 Issue No: 01





01.

**SPECIFY YOUR  
REQUIREMENTS**



02.

**PLACE YOUR  
ORDER**



03.

**STOCKS &  
MANUFACTURED  
IN OUR SPECIALISED  
FACILITY**



04.

**DESPATCHED  
QUICKLY**



05.

**DELIVERD DIRECTLY  
TO YOUR DOOR**

## Contents

01	CONTENTS PAGE	01
02	PLATINGS & COATINGS	
03	THREAD PITCH	
04	STUD BOLTS B7/ B8M	
05	HIGH STRENGTH BOLTS	
06	THREADED RODS	
07	ANCHOR/ FOUNDATION BOLTS	
08	BENT BOLTS / U BOLTS	
09	PVC CAPS / ANCHOR SLEEVES	
10	HOLLOW BOLT ANCHORS	
11	HVY SADDLE/ 2 PC CLAMP/ RISER CLAMP	
12	BOLTS / NUT / ANCHORS / RIGGINGS	
13	STEEL SECTION WEIGHT / SPANNER SIZE	
14	BENT BOLT ENQUIRY FORM	
15	ANCHOR FOUNDATION BOLTS	
16		
17		
18		
19		
20		
21		
22		
23		
24		
25		
26		
27		
28		
29		
30		



Xylan Green

## PLATING & COATINGS

We at Unifastner, as protective measure, recommend coating all fastners to protect against corrosin and lubricate them for longevity. We provide various types of coatings and platings to satisfy the customer's requirement. All coatings are applied at the time of manufacturing.

- ZINC PLATING
- CADMIUM PLATING
- DACROMET COATING
- PTFE / XYLAN COATING
- ZINC FLAKE
- MECHANICAL GALVANIZING
- HOT DIP GALVANIZING
- BLACK PHOSPHATE
- PVC / POWDER COATING

### XYLAN - BLUE & GREEN

Xylan coatings are frequently specified as the preferred option for improving the surface proper ties of offshore components. Xylan offers excellent corrosion and chemical resistance and works well under high loads and high temperatures. It will reduce significantly the friction coefficient of fasteners which facilitates even tension.

- Working temperature range -250°C to 285°C



HDG (left) compared with Mechanical Galvanised (right)

### HOT DIP GALVANISE (HDG)

A common treatment of high-tensile fasteners in which the material is submerged in molten zinc (above 450°C) producing a constant oxide coating that is formed in the final process as it becomes exposed to the atmosphere. The resulting galvanise coating is tough and durable, the process allows a consistent coating to internal and external surfaces providing excellent abra sion resistanc- es.

### Mechanical Galvanising

is also possible on our studs and fasteners. The benefit is a very uniform coating thickness reducing thread fit issues at assembly. Coating is done as per ASTM B 695

### ZINC

Zinc plating is used as a common light duty anti-rust protective coating, with it's high quality fin - ish and consistent thickness zinc plating can be used as a base for further PTFE coatings. Zinc plating will eliminate hydrogen embrittlement problems and blocked threads that can occur with fasteners that are exposed to increased pressure and temperature.

At unifastners we have fascility to do PVC Coating, Powder Coating, Black Phosphate and Zinc Flake Coatings at customers request.



B8M Strain Hardened



Xylan Blue

## THREAD PITCH

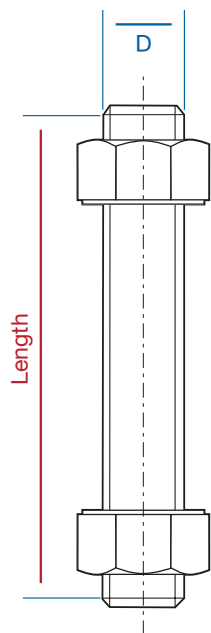

**QUALITY ASSURED**

### FULL THREAD STUDS

OUR STUD BOLT LENGTHS MEASURE FIRST THREAD TO FIRST THREAD. ENSURING THE CORRECT AMOUNT OF LEAD THREADS ARE STILL VISIBLE ONCE INSTALLED. THIS LENGTH IS CALCULATED BETWEEN CHAMFERED ENDS, A GUARANTEED SIGN OF QUALITY & CARE

Imperial (TPI) Threads Per Inch						Metric Thread Pitch		
Size	UNC	UN8	UNF	BSW	BSF	Size	Coarse	Fine
1/8"	40	-	44	40	-	M3	0.5	0.35
	32	-	36	-	-	M4	0.7	0.50
3/16"	24	-	32	24	32	M5	0.8	0.50
1/4"	20	-	28	20	26	M6	1	0.75
5/16"	18	-	24	18	22	M8	1.25	1
3/8"	16	-	24	16	20	M10	1.5	1.25
1/2"	13	-	20	14	18	M12	1.75	1.5
9/16"	12	-	18	12	16	M14	2	1.5
5/8"	11	-	18	11	14	M16	2	1.5
	-	-	-	-	-	M18	2.5	1.5
3/4"	10	-	16	10	12	M20	2.5	1.5
7/8"	9	-	14	9	11	M22	2.5	1.5
1"	8	8	12 (14)	8	10	M24	3	2
1 1/8"	7	8	12	7	9	M27	3	2
1 1/4"	7	8	12	7	9	M30	3.5	2
1 3/8"	6	8	12	6	8	M33	3.5	2
1 1/2"	6	8	12	6	8	M36	4	3
1 5/8"	-	8	-	5	8	M39	4	3
	-	-	-	-	-	M42	4.5	-
1 3/4"	5	8	-	5	7	M45	4.5	-
1 7/8"	-	8	-	-	-	M48	5	-
2"	4.5	8	-	4.5	7	M52	5	-
	4.5	8	-	4	6	M56	5.5	-
-	-	-	-	-	-	M60	5.5	-
2 1/2"	1	8	-	4	6	M64	6	-
2 3/4"	4	8	-	3.5	6	M72	6	-
3"	4	8	-	3.5	5	M80	6	-
3 1/4"	4	8	-	3.25	5	M-	-	-
3 1/2"	4	8	-	3.25	4.5	M90	6	-
3 3/4"	4	8	-	3	4.5	M-	-	-
4"	4	8	-	3	4.5	M100	6	-

## STUD BOLT AND NUTS

A stud bolt consists of one threaded steel rod and two (matching) hexagonal heavy steel nuts. Stud bolts and nuts are essential components of flanged joints, as they are key to seal flanged joints properly



Stud bolts are available in multiple diameters and lengths combinations, metric and imperial, and in a variety of materials from carbon steel to alloy, stainless and nickel alloys (common grades are: ASTM A193 B7, L7, B8, B8M, B16, The material of the hex steel nuts shall match the material of the threaded rod (generally, stud materials ASTM A193 match with nuts materials ASTM A194).

## STUD BOLT MATERIALS

The most common materials for stud bolts (for flanges) are ASTM A193 (grade B7, B8, B8M, B8T), ASTM A453 (grade 660), ASTM A320 (grade L7, L7M), and ASTM A182 (duplex and super duplex bolting). For aggressive fluids and environments, stud bolts can be coated with Xylan, Xylar and other materials.

### ASTM A193 STUD BOLTS (HIGH-TEMP.)

The ASTM A193 specification covers alloy-steel and stainless steel stud bolts materials for high temperature or high-pressure service.

The most common stud bolts materials covered by ASTM A193 are:

- ASTM A193 B7/ B7M: Alloy steel, AISI 4140/4142 quenched and tempered
- ASTM A193 B16
- ASTM A193 B8: Class 1 Stainless steel, AISI 304, carbide solution treated.
- ASTM A193 B8M: Class 1 Stainless steel, AISI 316, carbide solution treated.

### ASTM A320 STUD BOLTS (LOW-TEMP.)

The ASTM A320 specification covers alloy steel and Stainless Steel stud bolts materials for low-temperature service.

The most common stud bolts materials under ASTM A320 are listed below (low-temperature service):

- ASTM A320 L7/ L7M: Alloy steel, AISI 4140/4142 Quenched and tempered
- ASTM A320 B8 Class 1: Stainless steel, AISI 304, carbide solution treated
- ASTM A320 B8M: Class 1 Stainless steel, AISI 316, carbide solution treated



## DIAMETER & LENGTH CAPACITY :

4 mm to 170 mm for BOLTS & 200 mm for STUDS  
 Length upto 3.5 Meters

## CHEMICAL COMPOSITION OF FEW GRADES :

	ASTM A193 B7/B7M		ASTM A320 L7/L7M		ASTM A193 B16	
	Range	Variation Over/Under	Range	Variation Over/Under	Range	Variation Over/Under
Carbon	0.37 - 0.49	0.02	0.38 - 0.48	0.02	0.36 - 0.47	0.02
Manganese	0.65 - 1.10	0.04	0.75 - 1.00	0.04	0.45 - 0.70	0.03
Phosphorus	0.035 max	0.005 over	0.035 max	0.005 over	0.035 max	0.005 over
Sulfur	0.040 max	0.005 over	0.040 max	0.005 over	0.040 max	0.005 over
Silicon	0.15 - 0.35	0.02	0.15 - 0.35	0.02	0.15 - 0.35	0.02
Chromium	0.75 - 1.20	0.05	0.80 - 1.10	0.05	0.80 - 1.15	0.05
Molybdenum	0.15 - 0.25	0.02	0.15 - 0.25	0.02	0.50 - 0.65	0.03
Vanadium	-	-	-	-	0.25 - 0.35	0.03
Aluminium	-	-	-	-	0.015 max	-
Nickel	-	-	-	-	-	-
	ASTM A193 B6		ASTM A193 B8 CL1 & CL2		ASTM A193 B8M CL1 & CL2	
	Range	Variation Over/Under	Range	Variation Over/Under	Range	Variation Over/Under
Carbon	0.15 max	0.01 over	0.08 max	0.01 over	0.08 max	0.01 over
Manganese	1.00 max	0.03 over	2.00 max	0.04 over	2.00 max	0.04 over
Phosphorus	0.040 max	0.005 over	0.045 max	0.010 over	0.045 max	0.010 over
Sulfur	0.030 max	0.005 over	0.030 max	0.005 over	0.030 max	0.005 over
Silicon	1.00 max	0.05 over	1.00 max	0.05 over	1.00 max	0.05 over
Chromium	11.5 - 13.5	0.15	18.0 - 20.0	0.20	16.0 - 18.0	0.20
Molybdenum	-	-	-	-	2.00 - 3.00	0.10
Vanadium	-	-	-	-	-	-
Aluminium	-	-	-	-	-	-
Nickel	-	-	8.0 - 11.0	0.15	10.0 - 14.0	0.15

## MATERIAL SPECS OF HIGH & LOW TEMPERATURE BOLTING

Grade	Material	Min Tempering Temperature F (C)	Tensile strength (Min.)	Yield strength (Min.)	Elongation % (Min.)	Reduction % (Min.)	Brinell Hrdness	Recommended Bolting Temperature Range	
								Min. C	Max. C
ASTM A193 Gr. B7	ASTM 4140, 4142, 4145	1,100(593 C)	125 ksi / 860 Mpa	105 ksi / 720 Mpa	16	50	321 Max.	-100	400
ASTM A193 Gr. B7M	ASTM 4140, 4142, 4145	1,150(620 C)	100 ksi / 690 Mpa	80 ksi / 550 Mpa	18	50	235 Max.	-100	400
ASTM A320 Gr. L7	ASTM 4140, 4142, 4145	1,100(593 C)	125 ksi / 860 Mpa	105 ksi / 725 Mpa	16	50	321 Max.	-100 *	400
ASTM A320 Gr. L7M	ASTM 4140, 4142, 4145	1,150(620 C)	100 ksi / 690 Mpa	80 ksi / 550 Mpa	18	50	235 Max.	-100 *	400
ASTM A193 Gr. B16	Cr-Mo-Vanadium	1,200(650 C)	125 ksi / 860 Mpa	105 ksi / 725 Mpa	18	50	321 Max.	0	520
ASTM A193 Gr. B8	AISI 304	Carbide Solution Treated	75 ksi / 515 Mpa	30 ksi / 205 Mpa	30	50	223 Max.	-250	575
ASTM A193 Gr. B8M	AISI 316	Carbide Solution Treated	75 ksi / 515 Mpa	30 ksi / 205 Mpa	30	50	223 Mx.	-250	600
ASTM A320 Gr. B8	AISI 304	Carbide Solution Treated	75 ksi / 515 Mpa	30 ksi / 205 Mpa	35	50	223 Max.	-250	575
ASTM A320 Gr. B8M	AISI 316	Carbide Solution Treated	75 ksi / 515 Mpa	30 ksi / 205 Mpa	35	50	223 Mx.	-250	600

## WHY INSIST ON RF HIGH TENSILE HEXAGON HEAD BOLTS, SCREWS AND NUTS

### ADVANTAGES OF HIGH TENSILE FASTENERS: MAXIMUM STRENGTH WITH MINIMUM OF FASTENERS,

High Tensile Fasteners are forged to precision grade dimensions to ensure smooth assembly. In addition, heat treatment is done to suit the chemistry of every part of steel. This imparts optimum mechanical properties to ensure that correct tightening torques can be applied to fulfill design requirements.

#### ADVANTAGES

- Reduced Number of Bolts
- Reduced Bolt Size
- Less Numbers of Holes
- Reduced size of holes
- Reduced assembly cost
- Reduced Maintenance Cost



### ADVANTAGES OF HIGH TENSILE FASTENERS: MAXIMUM STRENGTH WITH MINIMUM OF FASTENERS,

STRENGTH GRADE	TENSILE GRADE	YIELD GRADE	YIELD INDEX (4.6 = 100)
4.6	400 MPa	240 MPa	100
5.8	500 MPa	400 MPa	166
6.8	600 MPa	480 MPa	200
8.8*	800 MPa	640 MPa	266
10.9*	1000 MPa	900 MPa	375
12.9*	1200 MPa	1080 MPa	450

It is obvious from the above table that High tensile Bolt of Property Class 8.8 is approximately four times stronger than ordinary Mild Steel Bolt of Property Class 4.6. This extra strength of High Tensile Bolt can be used to upgrade an assembled joint from a low tensile one to a high tensile one to gain all the advantages described above.

**Standard Specification** : BS 3692  
 Also conforms to ISO 4014, DIN 931 / 933  
**Material** : High Tensile Steel  
**Mechanical Properties** : BS 3692 / ISO 898 - 1  
**Strength Grade** : 8.8, 10.9  
**Screw thread** : 6g of ISO 965 / 2  
**Surface Finish** : Black Oxide, Zinc Plated  
 Hot Dipped Galvanized

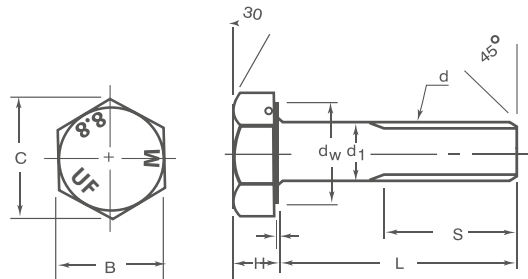
**DIMENSIONS**

Unit : mm

NOM SIZE d X p	d1		H		B		C		S		
	Max	Min	Max	Min	Max	Min	Max	Min	<= 125	>125<=200	>200
M6 X 1	6.0	5.82	4.150	3.850	10.0	9.78	11.5	11.05	18		
M8 X 1.25	8.0	5.82	5.650	5.350	13.0	12.73	15	14.38	22		
M10 X 1.5	10.0	9.78	7.180	6.820	17.0	16.73	19.6	18.90	26	32	
M12 X 1.75	12.0	11.73	8.180	7.820	19.0	18.67	21.9	21.10	30	36	49
M14 X 2	14.0	13.73	9.180	8.820	22.0	21.67	25.4	24.49	34	40	53
M16 X 2	16.0	15.73	10.180	9.820	24.0	23.67	27.7	26.75	38	44	57
M18 X 2.5	18.0	17.73	12.215	11.785	27.0	26.67	31.2	30.14	42	48	61
M20 X 2.5	20.0	19.67	13.215	12.785	30.0	29.67	34.6	33.53	46	52	65
M22 X 2.5	22.0	21.67	14.215	13.785	32.0	31.61	36.9	35.72	50	56	69
M24 X 3	24.0	23.67	15.215	14.785	36.0	35.38	41.6	39.98	54	60	73
M27 X 3	27.0	26.67	17.215	16.785	41.0	40.38	47.3	45.63	60	66	79
M30 X 3.5	30.0	29.67	19.260	18.740	46.0	45.38	53.1	51.28	66	72	85
M33 X 3.5	33.0	32.61	21.260	20.740	50.0	49.38	57.7	55.80	72	78	91
M36 X 4	36.0	35.61	23.260	22.740	55.0	54.26	63.5	61.31	78	84	97
M39 X 4	39.0	38.61	25.260	24.740	60.0	59.26	69.3	66.96	84	90	103
M42 X 4	42.0	41.61	26.260	25.740	65.0	64.26	75.1	72.61	90	96	109
M45 X 4.5	45.0	44.61	28.260	27.740	70.0	69.26	80.8	78.26	96	102	115
M48 X 5	48.0	47.61	30.260	29.740	75.0	74.26	86.6	83.91	102	108	121
M52 X 5	52.0	51.54	33.210	32.690	80.0	79.26	92.4	89.56	110	116	129

**Standard Specification** : ISO 4032  
 Also Conforms to BS 3692, DIN 934  
**Material** : Medium Carbon Steel  
**Mechanical Properties** : CI 8, 10  
**Threads** : Conforms to Class 6H of ISO 965 / 2  
**Surface Finish** : Black Oxide, Zinc Plated  
 Hot Dipped Galvanized

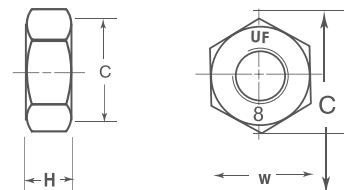
**DIMENSIONS**

Unit : mm

Nominal Size	Thread Pitch	W		C	H	
		Max	Min	Min	Max	Min
M8	1.25	13	12.73	14.38	6.8	6.44
M10	1.5	16	15.73	17.77	8.4	8.04
M12	1.75	18	17.73	20.03	10.8	10.37
M14	2	21	20.67	23.35	12.8	12.1
M16	2	24	23.67	26.75	14.8	14.1
M20	2.5	30	29.16	32.95	18	16.9
M24	3	36	35	39.55	21.5	20.2
M30	3.5	46	45	50.85	25.6	24.3
M36	4	55	53.8	60.79	31	29.4



## DTI WASHERS (Direct Tension Indicators)

- MADE TO ASTM F969 FOR USE WITH A325 AND A490 BOLTS
- PROVIDES HIGH CONSISTENT BOLT TENSION IN HEAVY HEX STRUCTURAL BOLTS

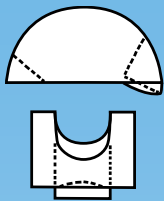

## HILLSIDE / SLOPE WASHERS

Structural Slope Washers for the Metal Building Industry

- CAST IRON ASTM A-48-83 CL-30 - AVAILABLE IN HOLE SIZES M12 / 16 / 20 / 22 / 24 / 27 / 30 / 33
- CAST IRON ASTM A-536-84 GR. 65-45-12

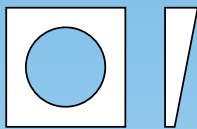

## TAPPER & SQUARE WASHERS

Structural Washers for use with A325 & A490 Structural Bolts

- HARDENED WASHERS ARE AVAILABLE TO ACCOMMODATE BOLT SIZES M10 - M30 DIA.
- SUPPLIED IN PLAIN FINISH TO ASTM SPEC F436 TYPE 1

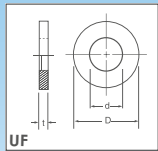

## HARDENED WASHERS

Standard Specification : ASTM F 436M  
 Material : Medium Carbon Steel  
 Hardness : Black Washer 38 ~45  
 HRC, HDG Washer 26 ~45  
 HRC  
 Surface Finish : Black, Zinc Plated Hot  
 Dipped Galvanized

Bolt Size	Inner Diameter (d)		Outer Diameter (D)		Thickness (t)	
	Max.	Min.	Max.	Min.	Max.	Min.
M12	14.40	14.00	27.00	25.70	4.60	3.10
M14	16.40	16.00	30.00	28.07	4.60	3.10
M16	18.40	18.00	34.00	32.40	4.60	3.10
M20	22.50	22.00	42.00	40.40	4.60	3.10
M22	24.50	24.00	44.00	42.40	4.60	3.40
M24	26.50	26.00	50.00	48.40	4.60	3.40
M27	30.50	30.00	56.00	54.10	4.60	3.40
M30	33.60	33.00	60.00	58.10	4.60	3.40
M36	39.60	39.00	72.00	70.10	4.60	3.40
M42	45.60	45.00	84.00	81.10	7.20	4.60



## HEAVY PLATE WASHERS

- Heavy plate washers weldable to anchor bolts are fabricated inhouse as per customer specifications.
- Available in range of thickness - 6MM to 25MM and square size 30x30 to 150x150
- Variety of finishes are available - WZP, HDG, CADMIUM, etc.



• FLAT WASHERS DIN125



• PENNY WASHERS DIN9021



• SPRING WASHERS DIN127



• NORDLOCK WASHERS



• HILL SIDE WASHERS



- Available Finishes**
- Bright Zinc Plated
  - Self Colour (unfinished)
  - Hot Spelter Galvanised
  - Yellow Passivated



**Threaded Bar Manufacturing**

Thread bar is typically manufactured through thread rolling -a process in which a blank bar/ wire rod is fed through a rotating die. Because the component is worked while cold, the threaded bars produced are with greater strengths, hardness and wear resistance.

A thread rolled part has a larger diameter than the rod itself from which it is made thus giving zero wastage and sometimes saving 15% in material costs than cut thread process. With cutting chamfering and thread rolling machines in-house at Unifastener we can produce & cut lengths from 50mm to 4000mm.

At Unifastener Our aim is to benefit you by delivering good quality products within your budget - on time first time and every time for ever.

- ◆ MILD STEEL    ◆ HIGH TENSILE GR 8.8    ◆ STAINLESS STEEL 304/ 316/ 316L
- ◆ ZINC PLATED    ◆ HOT DIP GALVANIZED    ◆ SELF COLOR    ◆ MECHANICAL HDG

### Grade 4.8, 8.8 & 10.9 High Tensile Steel Threaded Bar

- Wide range of diameter - M6 to M45
- choice of length up to 4 meter
- Pitch size from 1.00mm up to 4.5mm
- Choice of material - mild steel Gr.8.8/10.9 High Tensile Steel
- Also available stainless steel - 304/316/316L
- Choice of fully / partial / both side thread
- Choice of taper cut / V notch cut for Chemical anchor stud



Available Finishes  
 Bright Zinc Plated  
 Self Colour Galvanized  
 Hot Dip Galvanized  
 Polished  
 Stainless Steel

### 45° Angle Cut Bars

- Choose your material
- Choose your thread diameter
- Choose your bar length
- Choose your finish
- Choose your quantity



Type	Size	Finish
Grade 4.8	M6 to M60	Self Colour, Zinc Plated, Galvanised
Grade 8.8	M6 to M60	Self Colour, Zinc Plated, Galvanised
Grade 10.9	M6 to M60	Self Colour
A2/304	M6 to M30	Stainless Steel
A4/316	M6 to M30	Stainless Steel

### Tie Bars

- Choose your material
- Choose your thread diameter
- Choose your bar length
- Choose your thread length
- Choose one end or both ends
- Choose your finish
- Choose your quantity



Type	Size	Finish
Grade 4.8	M6 to M24	Self Colour, Zinc Plated, Galvanised
Grade 8.8	M6 to M24	Self Colour, Zinc Plated, Galvanised
Grade 10.9	M6 to M24	Self Colour
A2/304	M6 to M24	Stainless Steel
A4/316	M6 to M24	Stainless Steel

At Unifastener we can cut any type of threaded bar to suit your requirements. Whatever length or quantity you need, Simply tell us your requirement and we will remove the stress and hassle, delivering a high quality product to your door.

Across the company at Unifastener we are proactive in our approach to you. Our aim is to benefit you by delivering high quality products, within specification and in budget – on time, first time, every time.

- MILD STEEL • HIGH TENSILE STEEL • STAINLESS STEEL
- ZINC PLATED • SELF COLOURED • GALVANISED
- METRIC • UNC



Cut to length &  
Manufactured to order!

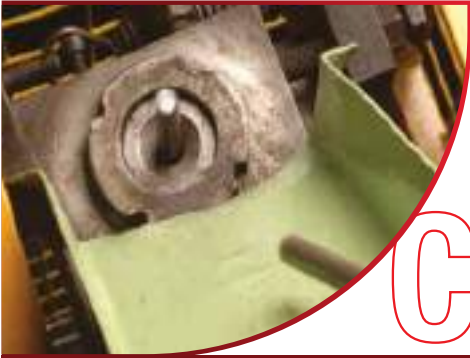

# CUT



# BEND



# ROLL



# FINISH

- U Bolts
- V Bolts
- L Bolts
- Eye Bolts
- Sling Hooks
- Hook Bolts
- Shackles
- Suspension Bolts
- Clamp Screws



## ANCHOR FOUNDATION BOLTS

Foundation Bolts are in different sizes, shapes and types. There are Eye Type, Tower Type, J and L types of the foundation bolts. Most common of these are L type & J type. Unifastener Industries LLC is a leading manufacturer and supplier of the Foundation Bolts and other types in all grades, shapes and sizes.

Material Grades:- Available in MS A36/ Gr4.6/ Gr8.8/ ASTM A193 Gr.B7/ F1554 Gr.36/55, SS-304/ 316.

Finish & Coatings:- As per requirements- White Zinc, Hot Dip Galvanized, Mechanical Zinc Plating, Yellow Zinc plated.

- Foundations Bolts – Straight / L- Type/ J- Type/ Eye- Type/ Hold down Type)
- Plate Welded/ Standard with Nut/ Washers assembled.
- Anchor Plates/ Base Plates/ Templates
- HDPE Anchor Sleeves  
Sag Rods



The use of foundation bolts is in the foundation of engineering structures. The Tower Foundations Bolts are mostly used with concrete structures in the erection of pillars, columns and the beginning of concrete structures. Depending on the application nature, the J Type Foundations Bolts can be used. These have a bend in the length but not at right angles. This is useful to distribute the stress even in the building structure or foundation. In other cases, the bolt has to be bent at right angles. The L Type Foundations Bolts are used for this type of need. Sometimes, the stress exerted on the bolt is very high and the bolt needs to have high tensile strength to withstand the tension. So the High Tensile Foundation Bolts are used in these circumstances. Please feel free to contact us for more information on the foundation bolts.

### HOLD DOWN ANCHOR BOLTS



Hold down bolts (or anchor rods) are a highly versatile product and can be configured in multiple ways included square or round hold down bolt cage assemblies. With several raw bar materials & threaded rods available they can be specified in mild or high tensile steel, or stainless-steel grades from M12 to M42 diameter commonly, or larger on request.

### WELDED ANCHOR PLATE & PLATE WASHERS



Anchor plates can be produced and fitted prior to delivery. Your specified shape plates can be tacked welded in place with nuts if required, or a fully welded. They are Provided finished usually in pre-galvanised parts, or fully galvanised after fabrication,

Typical rod dimension: Diameter (D) x Length (L) x Plate Position (A) x Thread (T)  
Typical plate dimension: Width (F) x Length (C) x Plate Thickness (H)

**ANCHOR BOLT DIMENSIONS**

ANCHOR THREAD DIAMETER	DIMENSIONS mm										CUTTING LENGTH mm										
	A	B	C	D	E	F	G	H	P		TYPE										
									SQUARE PLATE		S		SP	SQ		L		J		JE	
									T	W	L	L	L	CUT LENGTH	L	CUT LENGTH	L	CUT LENGTH	L	CUT LENGTH	
M12	40	16	40	45	100	-	50	29	10	75	330	330	355	381	355	455	410	542	-	-	
M16	50	19	40	55	100	-	65	35	12	90	400	400	355	384	355	455	420	595	-	-	
M20	60	22	50	70	150	50	75	39	12	90	480	480	405	442	405	555	485	705	355	575	
M22	70	25	50	75	150	55	80	48	16	100	570	570	460	498	460	610	545	787	415	657	
M24	85	28	55	90	200	65	90	55	20	100	700	700	510	553	510	710	610	874	475	739	
M27	-	-	75	100	200	75	-	-	-	-	-	-	560	610	560	760	673	970	535	832	
M30	100	36	75	115	200	85	110	64	20	125	820	820	610	667	610	810	735	1065	596	926	
M33	-	-	90	125	200	90	-	-	-	-	-	-	-	-	660	880	800	1163	655	1018	
M36	115	42	90	125	200	95	115	76	25	150	1010	1010	-	-	710	910	865	1261	715	1111	
M39	-	-	100	145	200	110	-	-	-	-	-	-	-	-	760	960	925	1354	770	1199	
M42	130	49	115	150	255	120	130	85	25	175	1120	1120	-	-	815	1070	990	1452	830	1292	
M48	150	56	125	180	255	125	-	-	-	-	-	-	-	-	915	1170	1120	1648	956	1484	
M56	170	63	140	200	255	145	-	-	-	-	-	-	-	-	1015	1270	1245	1861	1070	1686	
M64	190	70	160	220	255	160	-	-	-	-	-	-	-	-	1120	1375	1370	2074	1190	1894	

**Note:** Material: ASTM A36/JIS G3123/SS41 or AISI 1018 ss available (where the required sizes not available we use next size and thread area will be machined down to the required thread diameter.)  
**Nuts:** DIN 555 Class 5 or better (as available)  
**Surface Finish:** Natural or Hot Dip galv. (ASTM A 153). d = Body Diameter; In U Bolt- ID (Inside Diameter). T/L (Thread Length) and L (Total Length) as per customer requirements.

**BENT BOLT DIMENSIONS**

At UNIFASTENERS we produce anchor foundation bolts to your specifications. Our Anchor bolts are produced with all types of threads: coarse & Metric.

Threads may be cut thread or roll thread- when cut, the shank diameter is equal to the normal major diameter of threads; when rolled, the shank diameter is slightly smaller, roughly equivalent to the pitch diameter of threads.

We produce foundation bolts in Mild steel, High tensile Gr8.8/ 10.9 & B7 & stainless steel. Special services include full traceability, quick deliveries, special machining, plating and heat treating.

Corresponding nuts and washers are also available fitted upon request. Special thick Plate washers are also fabricated & welded as well upon request.

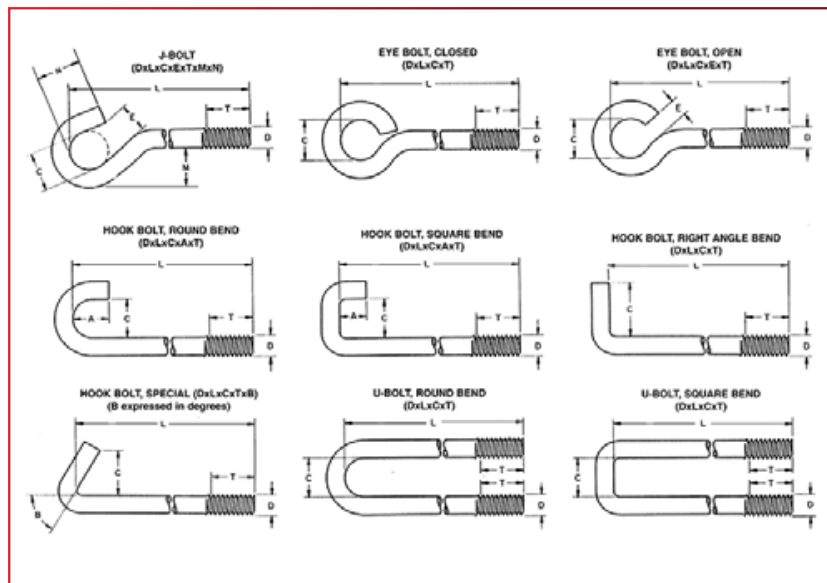

## ANCHOR BOLTS & BENT BOLTS COMMON PROJECTS AND APPLICATIONS

In August of 2007, F1554 grade 36 replaced ASTM A307 grade C which also covered mild steel anchor bolts.

### BRIDGES



Anchor bolts are used for bridge Applications including bearings, approach railings, and other critical components.

### STEEL BUILDINGS



Due to its versatility, it is used to support Steel Building columns & steel bearing plates.

### LIGHT RAIL



Anchor Bolts are increasingly used to support the poles of Rail lines & Tracks

### LIGHT POLES



Both Bent and Straight Anchor Bolts are common configurations in light pole foundation designs.

### TRAFFIC SIGNALS



Traffic Signal and Highway Lights often use large diameter Anchor Bolts to support large structures. These are usually Hot Dip Galvanized.

### INDUSTRIAL EQUIPMENT



Refineries, Oil & Gas facilities Ethanol Plants, Water treatment facilities & other use Anchor Bolts to secure equipment Pipe racking & steel structures.

### WATER STORAGE TANKS



Water storage towers and stand pipes Use Anchor rods & Bolt circles.

### SUBSTATIONS



Substations use large, Hot dip galvanized anchor bolts. They are used to hold large equipment, bus supports & static poles

### SOLAR STRUCTURES







Solar installations use anchor bolts to anchor solar arrays to concrete base Solar substations & Power equipment



Custom sizes just for you



All made to your specification or drawing

-  Choose your diameter
-  Choose your length
-  Choose your width
-  Choose your thread length

Standard Normal Bore 'U' Bolts	Pipe Normal Bore		No. 6203 Standard Leg 'U' Bolts			
	Metric	Imperial	A	B	C	D
½" = 15mm Pipe size (M6 Metric thread)	15NB	½"	M6	48mm	21mm	30mm
¾" = 20mm Pipe size (M6 Metric thread)	20NB	¾"	M6	53mm	27mm	30mm
1" = 25mm Pipe size (M6 Metric thread)	25NB	1"	M6	60mm	34mm	30mm
¾" = 25mm Pipe size (M8 Metric thread)	20NB	¾"	M8	45mm	27mm	25mm
½" = 15mm Pipe size (M8 Metric thread)	15NB	½"	M8	50mm	21mm	30mm
¾" = 25mm Pipe size (M8 Metric thread)	20NB	¾"	M8	53mm	27mm	25mm
¾" = 25mm Pipe size (M8 Metric thread)	20NB	¾"	M8	53mm	27mm	30mm
1" = 25mm Pipe size (M8 Metric thread)	25NB	1"	M8	64mm	34mm	30mm
1.¼" = 32mm Pipe size (M8 Metric thread)	32NB	1.¼"	M8	70mm	42mm	40mm
2" = 50mm Pipe size (M8 Metric thread)	50NB	2"	M8	90mm	60mm	40mm
½" = 15mm Pipe size (M10 Metric thread)	15NB	½"	M10	52mm	21mm	30mm
¾" = 20mm Pipe size (M10 Metric thread)	20NB	¾"	M10	55mm	27mm	30mm
1" = 25mm Pipe size (M10 Metric thread)	25NB	1"	M10	64mm	34mm	32mm
1.¼" = 32mm Pipe size (M10 Metric thread)	32NB	1.¼"	M10	70mm	42mm	40mm
1.½" = 40mm Pipe size (M10 Metric thread)	40NB	1.½"	M10	80mm	50mm	40mm
2" = 50mm Pipe size (M10 Metric thread)	50NB	2"	M10	90mm	60mm	40mm
2.½" = 65mm Pipe size (M10 Metric thread)	65NB	2.½"	M10	105mm	76mm	40mm
3" = 80mm Pipe size (M10 Metric thread)	80NB	3"	M10	116mm	90mm	40mm
4" = 100mm Pipe size (M10 Metric thread)	100NB	4"	M10	140mm	114mm	40mm
5" = 125mm Pipe size (M10 Metric thread)	125NB	5"	M10	168mm	140mm	40mm
6" = 150mm Pipe size (M10 Metric thread)	150NB	6"	M10	202mm	170mm	40mm
8" = 200mm Pipe size (M10 Metric thread)	200NB	8"	M10	268mm	220mm	60mm
2.½" = 65mm Pipe size (M12 Metric thread)	65NB	2.½"	M12	107mm	76mm	40mm
3" = 80mm Pipe size (M12 Metric thread)	80NB	3"	M12	116mm	90mm	40mm
4" = 100mm Pipe size (M12 Metric thread)	100NB	4"	M12	140mm	114mm	40mm
5" = 125mm Pipe size (M12 Metric thread)	125NB	5"	M12	170mm	140mm	40mm
6" = 150mm Pipe size (M12 Metric thread)	150NB	6"	M12	202mm	170mm	40mm
8" = 200mm Pipe size (M12 Metric thread)	200NB	8"	M12	270mm	220mm	60mm
10" = 250mm Pipe size (M12 Metric thread)	250NB	10"	M12	315mm	276mm	40mm
4" = 100mm Pipe size (M16 Metric thread)	100NB	4"	M16	143mm	112mm	50mm
5" = 125mm Pipe size (M16 Metric thread)	125NB	5"	M16	175mm	140mm	50mm
6" = 150mm Pipe size (M16 Metric thread)	150NB	6"	M16	205mm	170mm	55mm
8" = 200mm Pipe size (M16 Metric thread)	200NB	8"	M16	270mm	220mm	60mm

Material/Grade: \_\_\_\_\_

A (Diameter) \_\_\_\_\_

B (Inside Length) \_\_\_\_\_

C (Inside Width) \_\_\_\_\_

D (Thread Length) \_\_\_\_\_

Qty \_\_\_\_\_

Finish \_\_\_\_\_

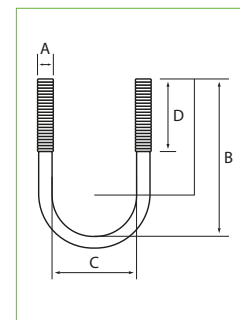
 No.6202 = Extended  
 No.6203 = Standard

**U Bolt**

See page 30 and fill in your requirements



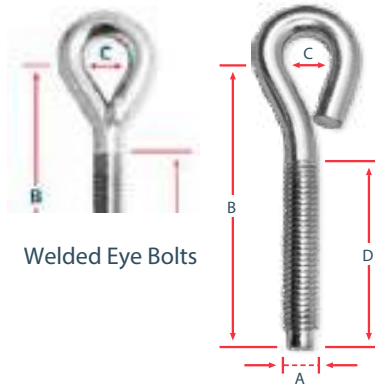

Welded Eye Bolts

No.6214

**Folded Eye Bolts**

Threaded Folded Eyebolts, commonly used for steel cable and for wire fencing support.

- Multiple finishes
- Unwelded eye
- Fully threaded

A	B	C	D
M6	To your requirements		
M8	To your requirements		
M10	To your requirements		
M12	To your requirements		
M16	To your requirements		

A = Diameter  
B = Length Centre Eye  
C = Eye Diameter  
D = Thread Length

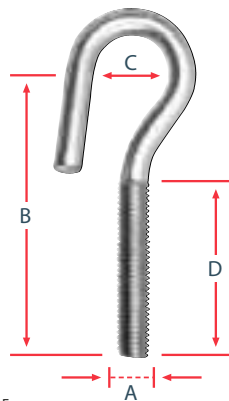

A = Diameter  
B = Length Centre Eye  
C = Eye Diameter  
D = Thread Length



No.6207

**Square U Bolt**

Square 'U' or 'C' Bolts are used for clamping square or rectangular items.

- Available in all sizes
- Manufactured to order

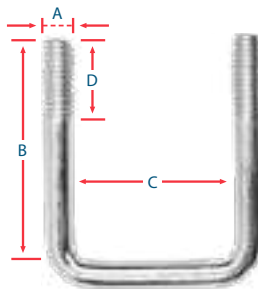

A = Diameter  
B = Length Centre Eye  
C = Eye Diameter  
D = Thread Length

No.6208

**V Bolt / Aerial Bolt**

V Bolts / Aerial Bolts can be used for multiple applications, most usually for clamping aerial poles and masts to brackets.

- Available in all sizes
- Manufactured to order

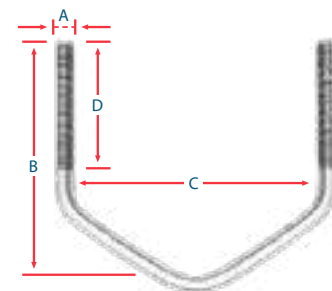

A = Diameter  
B = Length Centre Eye  
C = Eye Diameter  
D = Thread Length

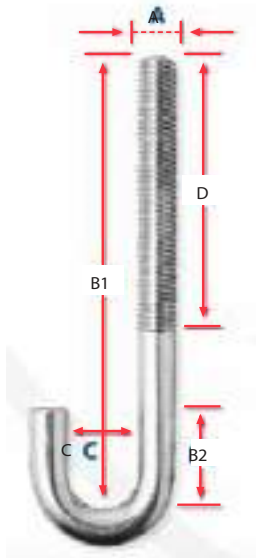

No.6204

### J Bolts

J Bolts are J shaped fasteners, threaded on the flat side. Often used in structural applications for structural components.

As a leading J Bolt manufacturer, A. Perry can manufacture specialty J Bolts to virtually any specification.

A	B1	B2	C	D
M6	To your requirements			
M8	To your requirements			
M10	To your requirements			
M12	To your requirements			
M16	To your requirements			

A = Diameter  
B1 = Inside Length 1  
B2 = Inside Length 2  
C = Eye Diameter  
D = Thread Length

Material/Grade: \_\_\_\_\_

A (Diameter)

B (Inside Length 1)

C (Inside Length 2)

D (Inside Width)

E (Thread Length)

Qty

Finish

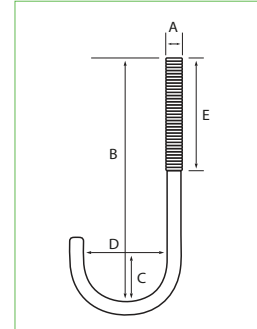

No. 6204

J Bolt

See page 30 and fill in your requirements

### C BENT BOLT WITH PLATE



- Rod Diameter
- U bolt Centre width
- U Bolt Height from inside
- Plate width
- Plate Thickness
- No of Holes..... Dia of Hole.....

### MUFLER / EXHAUST CLAMP

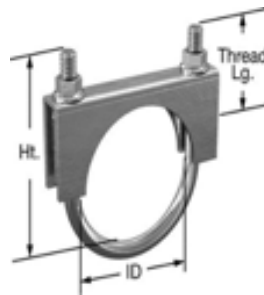

- ID INNER DIA of PIPE
- Ht U BOLT INNER HEIGHT
- Th. Lg. Thread length

### ONLY PLATE FOR U BOLT

- L Plate length
- W Plate Width & thickness
- H x B Hole size
- A Hole centre

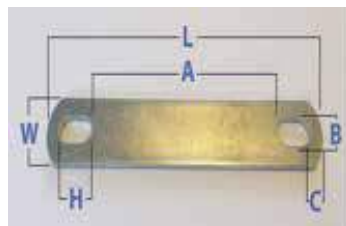

### U BOLT WITH PLATE

- U BOLT ROD DIA
- PIPE SIZE Inner dia
- U BOLT HEIGHT
- PLATE SIZE

People who bought this also bought

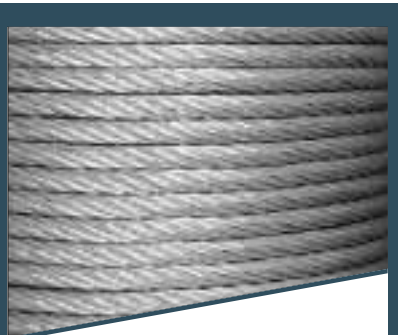

Wire Rope



Our wire rope products are used by practically all trades and industries for multiple purposes.

They are manufactured to meet customers' ever increasing and diverse needs and requirements.

See our Chains, Ropes & Accessories category on [www.perrytrade.co.uk](http://www.perrytrade.co.uk) or call your Account Manager today on +44 (0)1384 414001 and request your own copy of the catalogue.

You may need...

- Side Welded Steel Chain & Accessories
- Spiked Chain & Towing Chain
- Stainless Steel Chain
- Security Chain & Padlocks
- Polythene Chain & Accessories
- Wire Rope & Accessories
- Sisal Rope & Sash Cords
- Decking Rope & Accessories
- Polypropylene Rope

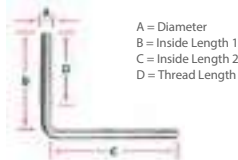

A = Diameter  
B = Inside Length 1  
C = Inside Length 2  
D = Thread Length

No.6209

**L Bolts**

L Bolts are commonly used to attach a plate member to concrete or masonry foundation and to provide an anchor for lightweight post bases and for other purposes.

No.6210

**Angle Hook Bolts**

Angle Hook Bolts allow the suspension of cables, wire, chains and other similar components. Typically used for roofing applications.

Custom sizes can be manufactured to order within a short lead time.

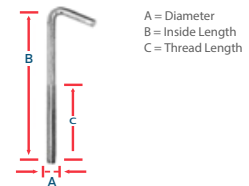

A = Diameter  
B = Inside Length  
C = Thread Length



A = Diameter  
B1 = Inside Length 1  
B2 = Inside Length 2  
C = Inside Width  
D = Thread Length

No.6219

**L Type Hook Bolts**

Often used in combination with square concrete purlins, C steel channel and H & I beams.

These hook bolts can be manufactured to order in various materials, finishes and sizes.

No.6212

**Clamp Screws**

Often used in 'C' Clamps, 'G' Clamps and Vice Screw Clamps.

- An industrial/commercial grade shackle ideal for light duty applications where the fixing is to be hand tightened.



A = Diameter  
B = Thread Length



A = Diameter  
B = Thread Length  
C = Inside Width  
D = Eye Diameter

No.6213

**U Shackles**

Smooth even 'U' prevents snagging and cable damage.

An industrial/commercial grade shackle ideal for light duty applications.

- Carbon Steel and SS
- Folded eye

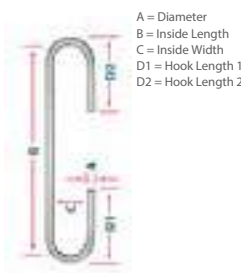

A = Diameter  
B = Inside Length  
C = Inside Width  
D1 = Hook Length 1  
D2 = Hook Length 2

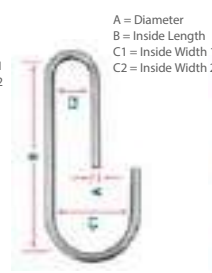

A = Diameter  
B = Inside Length  
C1 = Inside Width 1  
C2 = Inside Width 2

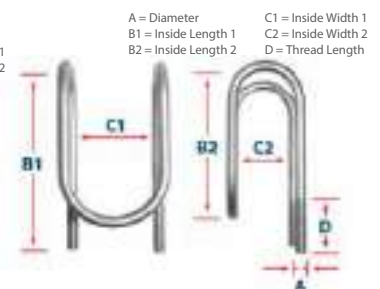

A = Diameter  
B1 = Inside Length 1  
B2 = Inside Length 2  
C1 = Inside Width 1  
C2 = Inside Width 2  
D = Thread Length

## Rubber Lined U Bolt

21 - 610 mm



## Advantages

U-bolt with neoprene rubber is excellent for eliminating corrosion problems on piping in refineries, chemical plants, paper mills, offshore platforms, rigs and the shipping industry. It is also excellent for shock absorption on plastic, FRP or glass-lined pipe and will help to reduce vibration and noise levels.

- Versatility – with a wide variety of sizes available, the U-Bolt complete set with neoprene rubber can be applied to all makes and sizes of U-Bolts.
- Protection – The rugged and a durable covering eliminate the metal to metal contact.
- Reliability – U-Bolt complete set with neoprene rubber provides high abrasive and corrosive resistance through a continuous sheath which eliminates fraying and unraveling. U-Bolt complete set with neoprene rubber is the virtually unaffected by heat, ultraviolet rays, vibration, electrolysis, sandblasting or any other rigors conducive to an industrial and marine environment.
- Easy of installation – The U-bolt size has been considered to accommodate the coating thickness assuring a secure fit over the pipe.

## Features and benefits

- High load capacity due to one piece design
- Supplied with two or four nuts
- Material: steel
- Electrogalvanized as per ASTM B 633 Standards (SC3)
- Noise insulating lining, rubber, black
- Special U bolts with longer tangents
- Threads available on request

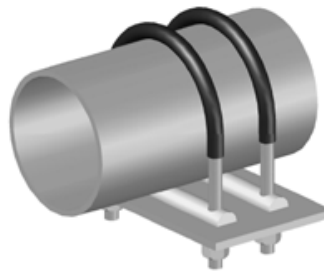

Part No.	D (mm)	D (")	G	H (mm)	Lm1 (mm)	F <sub>a,z</sub> (N)	Pack 1
DMC244022	21	½	M10	65	50	6,000	250
DMC244028	27	¾	M10	77	50	6,000	200
DMC244035	34	1	M10	85	50	6,000	200
DMC244042	43	1¼	M10	93	50	6,000	175
DMC244048	48	1½	M10	100	50	6,000	150
DMC244060	60	2	M10	110	50	6,000	150
DMC244075	76	2½	M12	127	50	10,000	100
DMC244090	89	3	M12	140	50	10,000	75
DMC244115	115	4	M12	165	50	10,000	75
DMC244140	140	5	M12	190	50	10,000	70
DMC244168	168	6	M12	220	50	10,000	50
DMC244219	219	8	M16	295	75	20,000	20
DMC244273	273	10	M20	370	100	32,500	10
DMC244324	324	12	M20	420	100	32,500	10
DMC244356	356	14	M20	455	100	32,500	10
DMC244406	406	16	M20	505	100	32,500	10
DMC244457	457	18	M24	555	100	45,000	5
DMC244508	508	20	M24	605	100	45,000	5
DMC244610	610	24	M24	710	100	45,000	5

Hot Dip Galvanized option available on request.  
 Alternate rod sizes for different pipe sizes available on request.

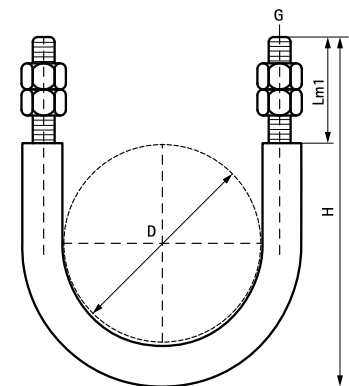

## Prevent Corrosion

This is a typical example of accelerated corrosion occurring due to metal contact between the uncoated U-Bolt and the pipe.

The excessive corrosion and pitting can eventually develop into pinhole leaks. This interaction can be completely eliminated by utilizing Unifastener insulated tube for the U-boats.

Unifasteners Insulated Tubes are excellent for eliminating corrosion problems on piping in Refinery, Chemical plants, offshore Rigs, Shipping industry, Construction & MEP industry. It is excellent for shock absorption on plastic, FRP & Glass lined Pipes etc.



### Physical Properties

Tensile Strength	1500 psi min.	ASTM D412
Elongation	300% min	ASTM D412
Heat Aging (168 hrs/121 °C)	1500 psi min	ASTM D2671
Tensile Elongation	300% min	ASTM D2671
Heat Shock	No cracks, flow or blisters	ASTM D2671
Low Temp. Flexibility (4hrs/-55 °C)	No cracking	ASTM D2671
Specific Gravity/ Temperature Limitation	0.96/200%	ASTM D792

### Chemical Properties

Water Absorption	0.2%	ASTM D570
Corrosive Effect (16hrs/175 °C)	Pass	ASTM D2671 /Copper Rod
Fluid Resistance (24hrs/25 °C)		
Hydraulic Fluid (MIL-H-5606C)		
Tensile	90% retained min	ASTM D412
Elongation	90% retained min	ASTM D412
Lubricating Oil (MIL-L-7808G)		
Tensile	90% retained min	ASTM D412
Elongation	90% retained min	ASTM D412
Diesel Fuel (MIL-L-23699)		
Tensile	90% retained min	ASTM D412
Elongation	90% retained min	ASTM D412

Performance Properties	Testing Method	Results
Adhesion	ASTM D 4541, ASTM D 3359	>800 PSI (test conducted on blasted substrate)
Hardness (Shore D)	ASTM D 2240	52
Impact Resistance	ASTM B 2794	>384 in./lbs.
Salt Spray Resistance	ASTM b-117	>2,000 hours
Humidity Resistance	ASTM D 2247	No blistering or loss of gloss after 1,000 hours
Taber Abrasion	ASTM D 4060	100 (mg loss, CS 17 wheel)
Mandrel Bend	ASTM D 522	1/8 inch, no cracks (>32%)
Melt Index	ASTM D 1238	207
Gloss	ASTM D 523	60 - 75

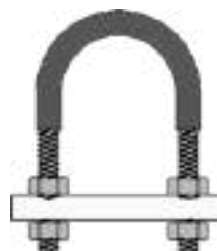

## WHAT ARE BOLT AND NUT PROTECTION CAPS?

For a long time, bolts and nuts on various facilities have long been exposed to wind, rain, hot & humid temperatures and soon be oxidized and lead to rust which needs maintenance & brings a lot of inconvenience especially after the corrosion, consuming lots of time, effort & resulting in great losses. See the middle picture below for ref. for benefit of using PVC Bolt & Nut caps.



Bolt And Nut Protection Caps are a plastic cover that conceals nuts and bolts to make them more resistant to weathering and tampering. These durable bolt and nut protection caps are resistant to most chemicals and protect fasteners from harsh weather conditions thus Giving Full protection to Bolt & Nut heads from extreme Rust They are designed to provide an enhanced finished appearance.



We are stocking different types of Bolt & Nut caps for Anchor bolts, Flange stud bolts, Thread rod end protectors etc The range includes black, white and grey bolt and nut protection caps. These LDPE nut and bolt protection caps are available in standard metric sizes (DIN 933) from M6 to M36 bolts, the range also includes :-

- Flange Stud Bolt caps,
- Double Nut Caps for anchor bolts,
- Extra Long Nut caps for Poles,
- Bolts caps with Reflective film for Glow in Night for Light & Traffic poles



### THREAD BAR END CAPS

We also Stock & supply Threaded Rod End caps to protect the Threads from damaging



#### SIZES

M6 to M24

## What is an anchor sleeve

Plastic anchor sleeves are a low cost and easy to install solution designed to solve the same problem while setting critical anchor bolts precisely into concrete. In the past, when alignment issues were an issue and the engineer on the job sought to prevent any fit problems after the concrete had set, they often used pipe or creating some sort of form to make a pocket or space that would allow for small manual adjustments to anchor itself after the concrete had been poured. These forms or pipe assemblies are labor intensive to create and often would slow down concrete pours. Unifastener Anchor Bolt Sleeves are perfect economical & time saving solution to these issues.

The Unifastener Anchor Bolt Sleeves are manufactured of high impact plastic. It is non-rusting, non-conductive and lightweight. An anchor sleeve allows a contractor the ability to adjust an anchor bolt slightly to fit the equipment base, steel structure, or other base that is attaching to the anchor bolt. They also allow for the creation of grout pockets for certain applications.



**Method of Installation:** The bottom of the sleeve is passed over the top of the bolt until the threaded portion engages the self-threading top of the sleeve. The sleeve is turned until the proper projection is obtained. The entire assembly is cast into the concrete, with the top of the sleeve at foundation level. When the anchor bolt is ready to adjust, the top of the sleeve is cut off and the top is discarded. The bolt may now be adjusted within the sleeve. Expansion or non shrinking grout is cast into the sleeve.

## Features

- Low cost, Quick & easy to install.
- Notched bolt hole design enables anchor bolt to self-thread and maintain a clean grout pocket that is free of water and dirt.
- Ribbed design provides for greater pullout strength.
- Enables quicker and easier final bolt alignment for heavy equipment and structural steel with lower costs & less labor.
- Eliminate the problems of custom prefitting, welding, pipe cutting, forming, packing and flame cutting mounting holes.
- Made of high-density polyethylene that's lightweight, non-conductive, and non-corrosive.

ANCHOR	MOUTH	SLEEVE	DIA
MM	MM	W X L	PCS / CRT
M16	17mm	2"x4"	100
M20	21mm	2"x4"	100
M20	21mm	2"x7"	100
M24	25mm	3"x6"	50
M27	28mm	3"x6"	50
M30	31mm	3"x6"	50
M33	34mm	3"x7"	50
M36	37mm	3"x7"	50
M40	41mm	3"x7"	50
M42	43mm	3"x7"	50
M45	46mm	3"x7"	50

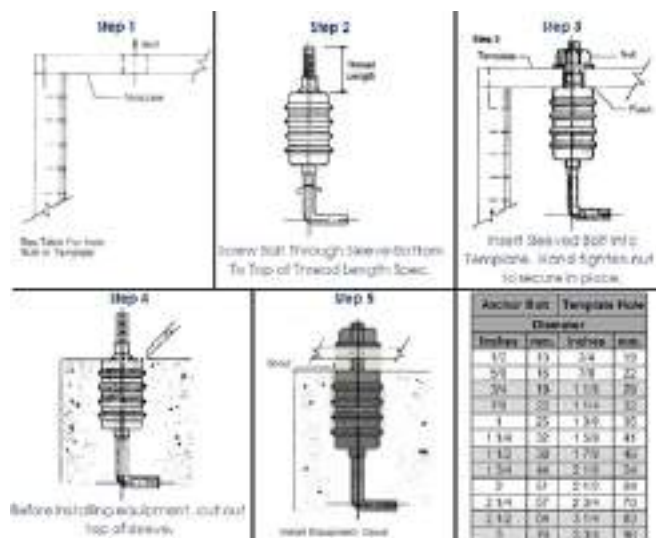

## Uni-Bolt

For Hollow Beams



Steel, bright zinc plated plus JS500  
Steel, sheraplex  
Steel, hot dip galvanised (Hex Head only)  
Stainless Steel Grade 316



## Hollow-Beam Bolt

Avoid the expense and save time to create access holes in structural hollow section & beams. The Uni-Hollow Bolt is a fast and easy solution for fastening hollow columns & beams when access is limited. The Uni bolt is simply inserted thru predrilled holes & tightened with a Torque wrench. The each size of bolt has its own clamping thickness.

Grade 8.8 Hi tensile Matl in HDG coating.

a) Hexagonal

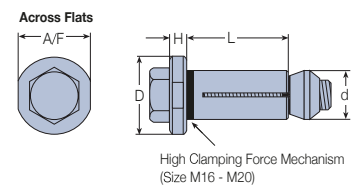

	a) HEXAGONAL		b) COUNTERSUNK		Clamping Thickness	Outer Ply <sup>1)</sup>	Sleeve Length	Outer Ø	Height	Collar Ø	A/F	Tightening Torque	Safe Working Loads <sup>2)</sup> (5:1 Factor of Safety)		
	Product Code	Bolt Length	Product Code	Bolt Length									Tensile kN	Single Shear kN	
		mm		mm									W mm	min t mm	L mm
	HB08-1	M8 x 50	HBCSK08-1	M8 x 50	3 - 22	-	30								
	HB08-2	M8 x 70	HBCSK08-2	M8 x 70	22 - 41	-	49	13.75	5	22	19	23	4.0	5.0	
High Clamping Force (HCF)	HB10-1	M10 x 55	HBCSK10-1	M10 x 50	3 - 22	-	30								
	HB10-2	M10 x 70	HBCSK10-2	M10 x 70	22 - 41	-	48	17.75	6	29	24	45	8.5	10.0	
	HB10-3	M10 x 90	HBCSK10-3	M10 x 90	41 - 60	-	67								
	HB12-1	M12 x 60	HBCSK12-1	M12 x 55	3 - 25	-	35								
	HB12-2	M12 x 80	HBCSK12-2	M12 x 80	25 - 47	-	57	19.75	7	32	30	80	10.5	15.0	
	HB16-1	M16 x 75	HBCSK16-1	M16 x 70	12 - 29	8	41.5								
HB16-2	M16 x 100	HBCSK16-2	M16 x 100	29 - 50	8	63	25.75	8	38	36	190	21.0	30.0		

### Installation

1. Align pre-drilled fixture and section and insert Holo-Bolt<sup>a)</sup>.

2. Apply installation nut and grip with an open ended adjustable spanner.

3. Using a calibrated torque wrench, tighten the central countersunk bolt to the recommended torque<sup>b)</sup>.

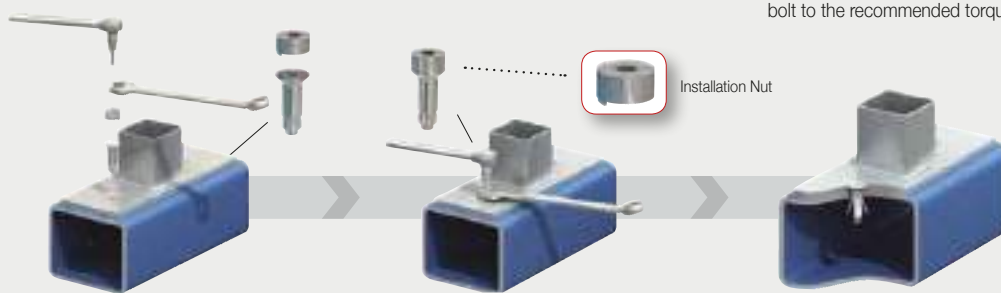

## PIPE HANGERS

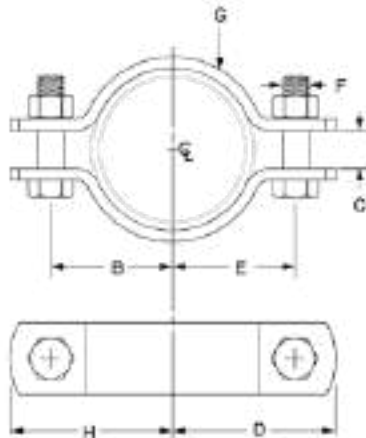

### PIPE CLAMP

#### Double Clamp

**SIZE:**

Range: 1/2" thru 6"

**FINISH:**

Electro-Galvanized &amp; Plain

**MATERIAL:**

Carbon steel

**FEATURES:**

- Maximum temperature Plain 650° F, Galvanized 450° F
- Designed for standard iron pipe
- Complies with Federal Specifications A-A-1192A (Type 8) and ANSI/SP-69 and SP-58 (Type 8)

#### Pipe Clamp: Loads (LBS) - Weights (LBS) - Dimensions (IN)

ITEM CODE 6000	ITEM CODE 6100	PIPE SIZE	MAX LOAD 650° F	MAX LOAD 750° F	WEIGHT	B	C	E	H	D	F	G WIDTH
6000-0050EG	6100-0050P	1/2	500	445	0.28	1 1/8	3/8	1 1/8	1 1/8	1 1/8	1/2	1
6000-0075EG	6100-0075P	3/4	500	445	0.32	1 1/4	7/8	1 1/4	1 1/8	1 1/8	1/2	1
6000-0100EG	6100-0100P	1	500	445	0.33	1 1/2	7/8	1 1/2	1 3/4	1 3/4	1/2	1
6000-0125EG	6100-0125P	1 1/4	500	445	0.35	1 3/4	7/8	1 3/4	2	2	1/2	1
6000-0150EG	6100-0150P	1 1/2	800	715	0.85	1 3/4	7/8	1 3/4	2 1/4	2 3/4	3/4	1
6000-0200EG	6100-0200P	2	1040	930	1.12	2 1/4	1 1/2	2 1/4	2 1/4	2 1/2	1/2	1
6000-0250EG	6100-0250P	2 1/2	1040	930	1.20	2 1/2	1 1/2	2 1/4	3 1/4	3 3/4	1/2	1
6000-0300EG	6100-0300P	3	1040	930	1.35	2 3/4	1 1/2	2 3/4	3 1/4	3 3/4	1/2	1
6000-0350EG	6100-0350P	3 1/2	1040	930	1.50	3 1/8	1 1/2	3 1/4	3 1/2	3 1/2	1/2	1
6000-0400EG	6100-0400P	4	1040	930	2.25	3 1/2	1 1/2	3 3/4	4 1/4	4 3/4	1/2	1
6000-0500EG	6100-0500P	5	1040	930	4.04	4 1/4	1 1/2	4 1/4	4 1/4	4 1/4	1/2	1 1/2
6000-0600EG	6100-0600P	6	1615	1440	5.39	4 3/4	1 1/2	4 3/4	6	6	1/2	1 1/2

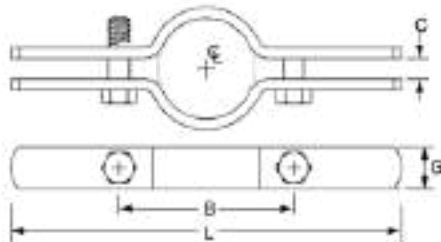

## RISER CLAMP

### Standard Riser Clamp

**SIZE:**

Range: 1/2" thru 24"

**FINISH:**

Electro-Galvanized & Plain

**MATERIAL:**

Carbon steel

**FEATURES:**

- Maximum temperature Plain 650° F, Galvanized 450° F
- Designed for standard iron pipe
- Complies with Federal Specifications A-A-1192A (Type 8) and ANSI/SP-69 and SP-68 (Type 8)

**Riser Clamp - Plain & Galv.:**

**Loads (LBS) · Weights (LBS) · Dimensions (IN) · Torque Values (FT-LBS)**

ITEM CODE 6300	ITEM CODE 6200	TUBE SIZE	MAX LOAD	WEIGHT	L	G WIDTH	B	C	BOLT SIZE	TORQUE VALUES
6300-0050P	6200-0050EG	1/2"	220	0.80	9	1	2 1/4	1 1/4	1/4	19
6300-0075P	6200-0075EG	3/4"	220	0.80	9	1	2 1/4	1 1/4	1/4	19
6300-0100P	6200-0100EG	1"	220	1.04	9	1	3 1/4	1 1/4	1/4	19
6300-0125P	6200-0125EG	1 1/4"	250	1.06	9 1/4	1	3 1/2	1 1/4	1/4	19
6300-0150P	6200-0150EG	1 1/2"	250	1.08	10	1 1/4	3 1/4	1 1/4	1/4	19
6300-0200P	6200-0200EG	2"	300	1.16	10 1/4	1 1/4	4 1/4	1 1/2	1/4	19
6300-0250P	6200-0250EG	2 1/2"	400	1.32	11	1 1/4	4 1/4	1 1/2	1/4	19
6300-0300P	6200-0300EG	3"	500	1.56	11 3/4	1 1/4	5 1/2	1 1/2	1/4	19
6300-0350P	6200-0350EG	3 1/2"	600	1.70	12 1/2	1 1/4	6 1/4	1 1/2	1/4	19
6300-0400P	6200-0400EG	4"	750	1.70	13	1	7	1 1/2	1/2	50
6300-0500P	6200-0500EG	5"	1500	3.45	14	1 1/4	8	1 1/2	1/2	50
6300-0600P	6200-0600EG	6"	1600	3.70	15 1/4	1 1/2	9	1 1/2	1/2	50
6300-0800P	6200-0800EG	8"	2500	7.40	18 1/4	1 1/2	12	1 1/4	1/4	50
6300-1000P	6200-1000EG	10"	2500	11.00	20	2	13 1/4	1 1/4	1/4	65
6300-1200P	6200-1200EG	12"	2700	16.25	22 1/4	2	15 1/4	1 1/4	1/4	65
6300-1400P	6200-1400EG	14"	2700	17.00	25	2	17 1/4	1 1/4	1/4	65
6300-1600P	6200-1600EG	16"	3200	18.50	26 1/2	2 1/2	19 1/4	1 1/4	1/4	150
6300-1800P	6200-1800EG	18"	3200	28.00	28	2 1/2	21 1/4	1 1/4	1/4	150
6300-2000P	6200-2000EG	20"	3200	43.40	30	2 1/2	23 1/4	1 1/4	1/4	150
6300-2400P	6200-2400EG	24"	3200	82.00	36 1/4	3	30	1	1/4	190

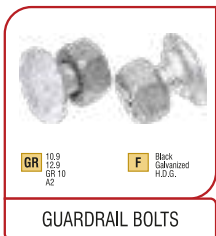
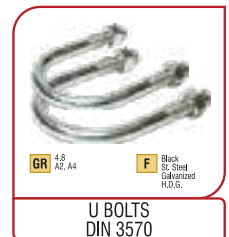
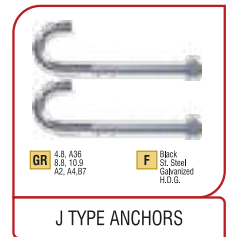
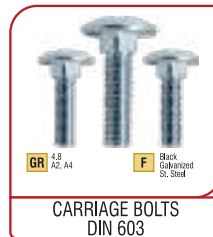
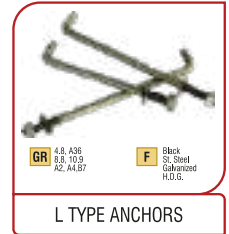

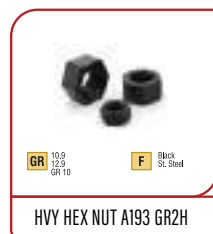
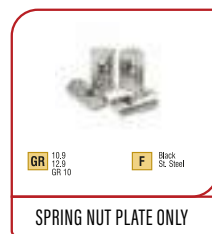
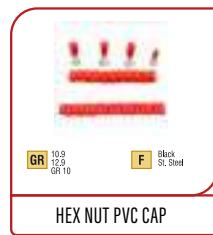
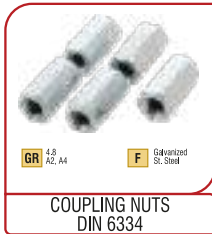

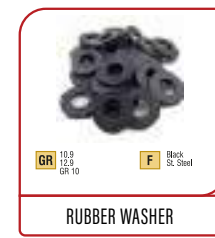
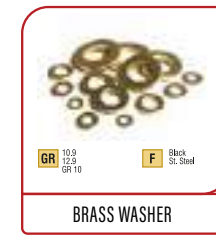

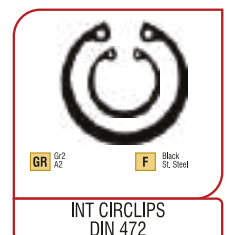
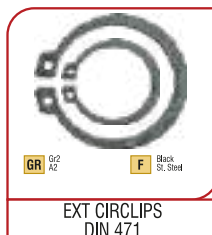
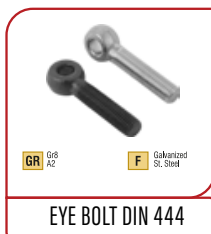
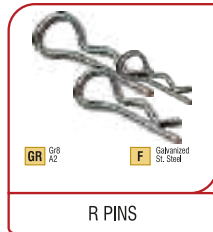

**ANCHORS**

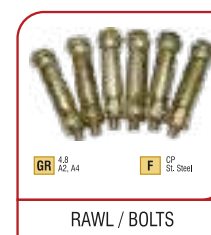
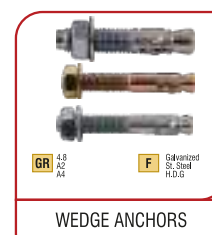

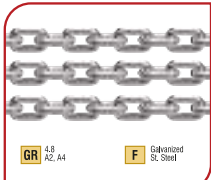

GR 4.8 A2, A4 F Galvanized St. Steel

LINK CHAINS

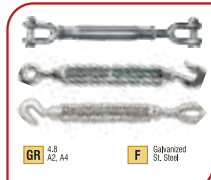

GR 4.8 A2, A4 F Galvanized St. Steel

TURN BUCKLES

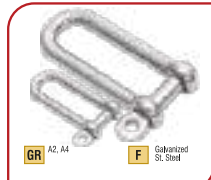

GR A2, A4 F Galvanized St. Steel

D SHACKLES



GR 4.2 A2, A4 F Same Wall Galvanized St. Steel

LIFTING EYE BOLT/NUTS  
DIN 580/582



GR 4.8 A2 F Galvanized St. Steel

SNAP HOOKS



GR 4.8 A2 F Galvanized St. Steel

WIRE ROPES

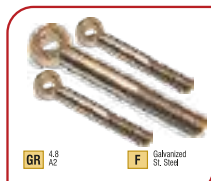

GR 4.8 A2 F Galvanized St. Steel

EYE BOLTS

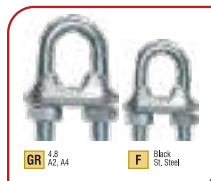

GR 4.8 A2, A4 F Black St. Steel

WIRE ROPE CLIPS



GR 4.8 A2, A4 F Galvanized St. Steel

S.S QUICK LINK



GR 10.9 12.9 GR 10 F Black St. Steel

BOW SHACKLES



GR F

TEFLON SHEETS



GR F

NYLON/PTEF RODS



GR 10.9 12.9 GR 10 F Black St. Steel

LIFTING EYE BOLT  
DIN580



GR 10.9 12.9 GR 10 F Black St. Steel

WELD STUD DIN 32501



GR 10.9 12.9 GR 10 F Black St. Steel

NYLON BOLTS

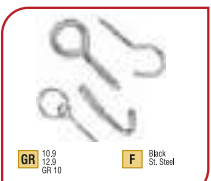

GR 10.9 12.9 GR 10 F Black St. Steel

HOOK/ EYE BOLT



GR 10.9 12.9 GR 10 F Black St. Steel

J/ L/ ANGLE HOOK



G80 HEAVY LOAD MS CHAIN



NON ROTATING WIRE ROPE



PVC COATED WIRE ROPE



ALUMINIUM FERRULE



THIMBLE



WIRE ROPE SLINGS



CP CHAIN/ BP CHAIN

## WEIGHT CHARTS FOR STEEL BAR

### ROUND BAR



DIA OF BAR MM	KGS PER METER
6	0.22
8	0.40
9	0.50
10	0.62
11	0.75
12	0.89
13	1.04
14	1.21
15	1.39
16	1.58
18	2.00
19	2.23
20	2.47
22	2.98
24	3.55
25	3.85
27	4.49
28	4.83
30	5.55
32	6.31
33	6.71
35	7.55
36	7.99
38	8.90
40	9.86
42	10.87
45	12.48
48	14.20
50	15.41
52	16.67
55	18.65
56	19.33
58	20.74
60	22.19
62	23.70
64	25.25
65	26.05
68	28.51
70	30.21
72	31.96
75	34.68
80	39.45

### SQUARE BAR



SIZE MM	KGS PER METER
13	1.33
14	1.54
15	1.77
16	2.01
18	2.54
19	2.83
20	3.14
22	3.80
25	4.91
28	6.15
30	7.06
32	8.04
35	9.62
38	11.33
40	12.56
45	15.89
50	19.62
57	25.50
65	33.16
70	38.46
75	44.15
83	54.07
90	63.58
95	70.84
102	81.66
110	94.97
115	103.80
130	132.65
140	153.84
150	176.60
160	200.93
165	213.69
170	226.84
180	254.31
190	283.35
200	313.96
220	379.89
230	415.21
240	452.10
255	510.38

### FLAT BAR



SIZE MM	KGS PER METER	SIZE MM	KGS PER METER
20 X 5	0.79	80 X 5	3.14
20 X 10	1.57	80 X 10	6.28
20 X 15	2.36	80 X 15	9.42
25 X 5	0.98	80 X 20	12.60
25 X 10	1.96	80 X 25	15.70
25 X 15	2.94	90 X 5	3.53
30 X 5	1.12	90 X 10	7.07
30 X 10	2.36	90 X 15	10.60
30 X 15	3.53	90 X 20	14.10
35 X 5	1.37	90 X 25	17.70
35 X 10	2.75	100 X 5	3.93
35 X 15	4.12	100 X 10	7.85
40 X 5	1.57	100 X 15	11.80
40 X 10	3.14	100 X 20	15.70
40 X 15	4.71	100 X 25	19.60
40 X 20	6.28	100 X 40	31.40
40 X 25	7.85	120 X 10	9.42
45 X 5	1.77	120 X 15	14.10
45 X 10	3.53	120 X 20	18.80
45 X 15	5.30	120 X 25	23.60
45 X 20	7.07	120 X 40	37.70
45 X 25	8.83	130 X 10	10.20
50 X 5	1.96	130 X 15	15.30
50 X 10	3.93	130 X 20	20.40
50 X 15	5.89	130 X 25	25.50
50 X 20	7.85	130 X 40	40.80
50 X 25	9.81	140 X 10	11.00
60 X 5	2.36	140 X 15	16.50
60 X 10	4.71	140 X 20	22.00
60 X 15	7.07	140 X 25	27.50
60 X 20	9.42	140 X 40	44.00
60 X 25	11.80	150 X 10	11.80
65 X 5	2.55	150 X 15	17.70
65 X 10	5.10	150 X 20	23.60
65 X 15	7.65	150 X 25	29.40
65 X 20	10.20	150 X 40	47.10
65 X 25	12.80	160 X 10	12.60
70 X 5	2.75	160 X 15	18.80
70 X 10	5.50	160 X 20	25.10
70 X 15	8.24	160 X 25	31.40
70 X 20	11.00	160 X 40	50.20
70 X 25	13.70	160 X 50	62.80

### HEXAGON BAR



SIZE MM	KGS PER METER
10	0.68
11	0.82
12	0.98
13	1.15
14	1.33
15	1.53
16	1.74
17	1.96
18	2.20
19	2.45
20	2.72
22	3.29
24	3.92
25	4.25
27	4.96
30	6.12
32	6.96
36	8.81
40	10.90
41	11.40
46	14.40
48	15.70
50	17.00
52	18.40
55	20.60
60	24.50
65	28.70
70	33.30
76	39.30

<b>Spanner &amp; Hex Key Sizes for Sets/Bolts and Socket Caps</b>		
<b>Size</b>	<b>Spanner Size</b>	<b>Hex Key Size</b>
M8	13mm	6mm
M10	17mm	8mm
M12	19mm	10mm
M14	22mm	12mm
M16	24mm	14mm
M18	27mm	14mm
M20	30mm	17mm
M24	36mm	19mm
M27	40mm	19mm
M30	45mm	21mm
M33	49mm	23mm
M36	54mm	26mm
M39	59mm	27mm
M42	64mm	31mm
M45	69mm	32mm

BLACK & GALVANIZED STEEL TUBES CONFORMING TO IS : 1239(I) EQUIVALENT TO BS:1387  
& STRUCTURAL TUBES CONFORMING TO IS: 1161

SERIES			LIGHT					MEDIUM				
NOMINAL BORE		O.D.	OUTSIDE DIA.		WALL THICK.	WEIGHT		OUTSIDE DIA.		WALL THICK.	WEIGHT	
INCH	mm	mm	(MIN.) mm	(MAX.) mm	mm	P/E Kg/m	S/S Kg/m	(MIN.) mm	(MAX.) mm	mm	P/E Kg/m	S/S Kg/m
1/2	15	21.3	21.0	21.4	2.0	0.947	0.958	21.0	21.8	2.6	1.21	1.22
3/4	20	26.9	26.4	26.9	2.3	1.38	1.39	26.5	27.3	2.6	1.56	1.57
1	25	33.7	33.2	33.8	2.6	1.98	2.00	33.3	34.2	3.2	2.41	2.43
1-1/4	32	42.2	41.9	42.5	2.6	2.54	2.57	42.0	42.9	3.2	3.10	3.13
1-1/2	40	48.3	47.8	48.4	2.9	3.23	3.27	47.9	48.8	3.2	3.56	3.60
2	50	60.3	59.6	60.2	2.9	4.08	4.15	59.7	60.8	3.6	5.03	5.10
2-1/2	65	76.1	75.2	76.0	3.2	5.71	5.80	75.3	76.6	3.6	6.42	6.54
3	80	88.9	87.9	88.7	3.2	6.72	6.89	88.0	89.5	4.0	8.36	8.53
4	100	114.3	113.0	113.9	3.6	9.75	10.00	113.1	115.0	4.5	12.20	12.50
5	125	139.7	-	-	4.5	15.00	-	138.5	140.8	4.8	15.90	16.40
6	150	165.1	-	-	4.5	17.60	-	163.9	166.5	4.8	18.90	19.50
6	150	168.3	-	-	4.5	18.20	-	-	-	4.8	19.40	-
6	150	168.3	-	-	-	-	-	-	-	-	-	-
7	175	193.7	-	-	4.8	22.40	-	-	-	5.4	25.10	-
8	200	219.1	-	-	4.8	25.40	-	-	-	5.6	29.50	-
10	250	273.0	-	-	-	-	-	-	-	-	-	-
12	300	323.9	-	-	-	-	-	-	-	-	-	-
14	350	355.6	-	-	-	-	-	-	-	-	-	-

**ROLL THREADED ENGINEERED FASTENERS SPECIAL ENQUIRIES**

Material Grade: \_\_\_\_\_

A (Diameter)

B (Inside Length)

C (Thread Length)

Quantity

Finish

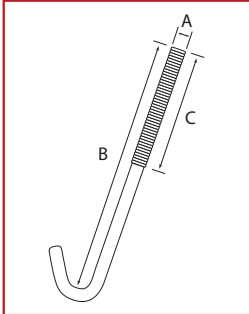

No.6210 Hook Bolt

Material Grade: \_\_\_\_\_

A (Diameter)

B (Inside Length)

C (Inside Width)

D (Thread Length)

Quantity

Finish

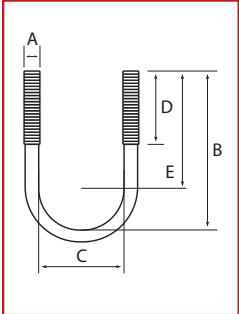

No.6202 = Extended  
No.6203 = Standard

U Bolt

Material Grade: \_\_\_\_\_

A (Diameter)

B (Inside Length 1)

C (Inside Length 2)

D (Inside Width)

E (Thread Length)

Quantity

Finish

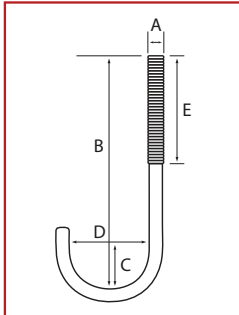

No.6204 J Bolt

Material Grade: \_\_\_\_\_

A (Diameter)

B (Inside Length)

C (Inside Width)

D (Thread Length)

Quantity

Finish

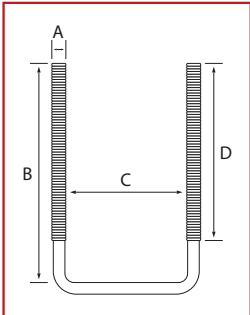

No.6207 Square U Bolt

Material Grade: \_\_\_\_\_

A (Diameter)

B (Length Centre Eye)

C (Eye Diameter)

D (Thread Length)

Quantity

Finish

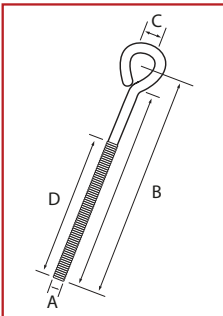

No.6214 Folded Eye Bolt

Date: \_\_\_\_\_

Company Name: \_\_\_\_\_

Contact: \_\_\_\_\_

Tel: \_\_\_\_\_

Email: \_\_\_\_\_

Customer Signature: \_\_\_\_\_

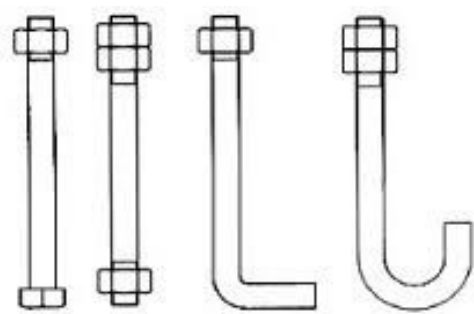
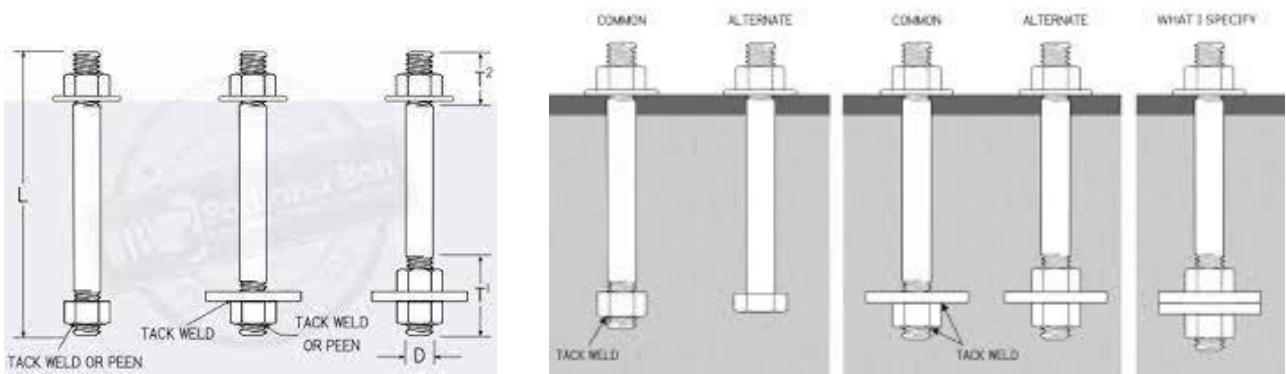

## ANCHOR BOLT CONFIGURATIONS

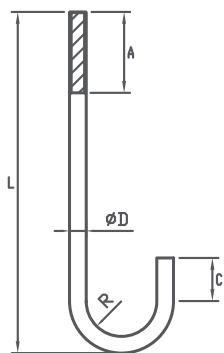

"J" SHAPE

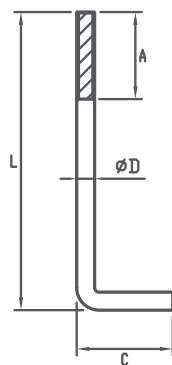

"L" SHAPE

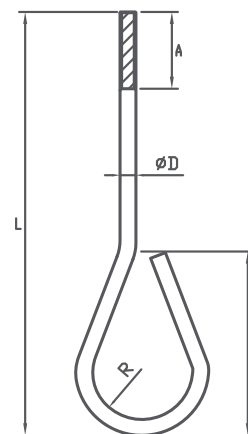

EYE SHAPE





**UNIFASTENER INDUSTRIES LLC**

Unifastener Industries LLC, an ISO 9001:2015 (QMS) CERTIFIED COMPANY is among one of the few Fastener manufacturing company having a complete State of the art testing facility which is not only covering the mechanical testing aspect of fasteners but also for The chemical testing as well, we are committed to producing components of the Highest possible quality. this is achieved through the rigorous checks performed by our dedicated and Experienced Quality Control Department in line with the procedures laid down in our Quality and Procedures Manual. Only products which have passed all the relevant quality checks are marked with our "AB" Identification symbol. The professionalism and competence of our highly Qualified staff guarantees the conformity of all our Components to the required specifications.





 050 770 7528 / 054 321 8371 

 [info@unifastenerind.com](mailto:info@unifastenerind.com)

 P.O.BOX: 42257  
Shed #5 & 6, New Industrial Area,  
Umm Dearaa, Umm Al Quwain, U.A.E

 [www.unifastenerind.com](http://www.unifastenerind.com)

Contact Details

