

# KATCO

**KHALID AL ARABID RT CO LLC**  
شركة خالد العرابيد التجارية ذ.م.م

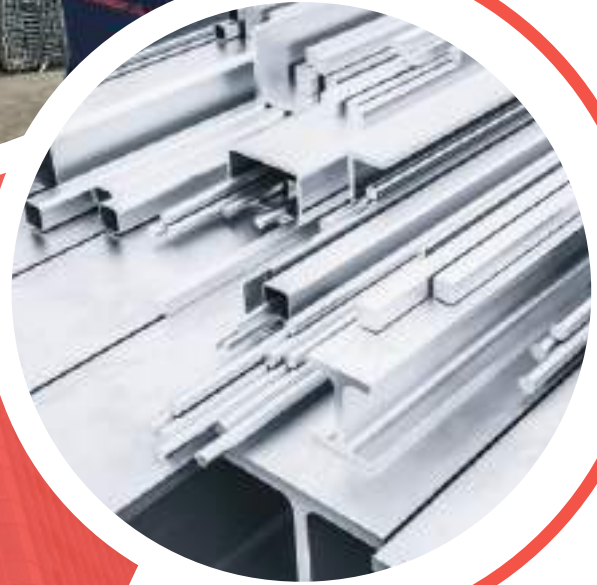

Committed To  
Superior  
Quality & Result

[www.katco.ae](http://www.katco.ae)



## Content

Introduction	03
Material Specification	05
55MM/80MM Sliding Door & Windows	06
100MM Umberlla Sliding Door & Windows	07
100MM Box Umberlla Sliding Door & Windows	08
105MM Sliding Umberlla Inside Fyscreen Profiles	09
42MM Hinged Door & Window	10
Louvers, Amplimesh & Joint Floor	12
45MM Hinged Profiles	13
Curtainwall	16
Corner Cleat Profiles	18
Balustrades	19
Kitchen Cabinet Profiles	24
Showcase Profiles	25
ALLCO 5 System (1.5MM+1.8MM)	26
55MM Hinged Thermal Break AREXCO	28
105MM Hinged Thermal Break AREXCO	30
120MM Hinged Thermal Break AREXCO	31
Folding Door System	34
Accessories	35
<i>Handles   Hinges   Locks   Rollers   Double Glass Accessories   Aluminium Accessories</i>	
<i>Aluminium Accessories   Tools   Kitchen Items   Plastic Items   Screws &amp; Rivets   Patch Fitting</i>	



# KATCO

## Introduction

KATCO, short for Khalid Al Arabid RT. Co. LLC., is a renowned company in the UAE specializing in aluminium profiles systems, glass, and accessories. With a legacy dating back to the 1970s, we have been at the forefront of the industry, providing top-quality products and services to our esteemed clients. Our commitment to excellence and customer satisfaction has allowed us to expand our reach across Africa, where we have established thriving branches.

## Mission

Our mission at KATCO is to be the preferred choice for all aluminium profiles system, glass, and accessories needs in the region. We strive to continuously innovate and improve our products and services to exceed customer expectations and set new industry standards. We aim to build lasting relationships with our clients based on trust, reliability, and excellence.

## Vision

Our vision at KATCO is to be a global leader in the aluminium profiles system, glass, and accessories sector, known for our unparalleled quality, innovation, and customer-centric approach. We aim to drive the industry forward by introducing cutting-edge products and solutions that cater to the evolving needs of our clients. We envision a future where KATCO plays a pivotal role in shaping the landscape of the industry, setting new benchmarks for excellence.



**ALUMINIUM**

**KATCO**



**ALUMINIUM  
PACKING**



**ALUMINIUM  
LOADING**



## Material Specification

### CHEMICAL COMPOSITION & MECHANICAL PROPERTIES OF ALLOY 6063 & 6061 IN TEMPER T5 & T6

#### CHEMICAL COMPOSITION

	<u>Alloy 6063</u>		<u>Alloy 6061</u>	
Mg	0.45 - 0.90	%	0.80 - 1.20	%
Si	0.20 - 0.60	%	0.40 - 0.80	%
Cr	0.10	%	0.04 - 0.35	%
Zn	0.10	%	0.25	%
Fe	0.35	%	0.70	%
Cu	0.10	%	0.15 - 0.40	%
Mn	0.10	%	0.15	%
Ti	0.10	%	0.15	%
Other Impurities	0.05	%	0.50	%
Aluminium	REMAINDER		REMAINDER	

#### MECHANICAL PROPERTIES

		<u>Alloy 6063</u>		<u>Alloy 6061</u>	
		<u>T5</u>	<u>T6</u>	<u>T5</u>	<u>T6</u>
Ult. Tensile Strength	N/mm <sup>2</sup>	150	185	190	280
0.2% Proof Stress	N/mm <sup>2</sup>	110	160	115	240
Hardness (Brinell)	BHN	55	75	60	90
Ult. Shear Strength	N/mm <sup>2</sup>	155		205	
Elongation on 50 mm	%	8		8	
Density	g/cm <sup>3</sup>	2.7		2.7	
Melting Range	Deg.C.	600 - 650		580 - 650	
Coefficient of Linear Expansion	X10 <sup>-6</sup> /Deg.C.	23		24	
Modulus of Elasticity	N/mm <sup>2</sup>	67000		69000	
Fatigue Strength (50 x 10 <sup>6</sup> cycles)	N/mm <sup>2</sup>	75		95	

## Associate Partners



## 55MM SLIDING DOORS & WINDOWS







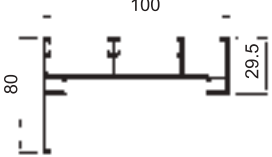
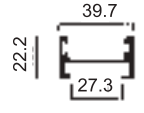
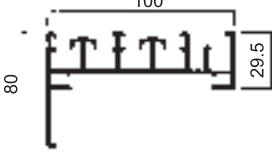
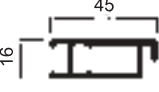
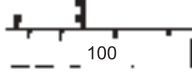
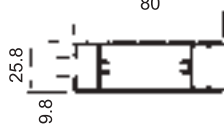
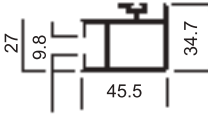
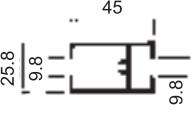
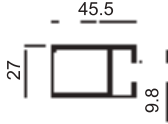







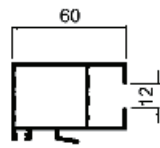

## 80MM SLIDING DOORS & WINDOWS

Sec. No.	PROFILE	Sec. No.	PROFILE
1498 (0.616kg/m)		09108 (1.00 Kg/m)	
1499 (0.726kg/m)		09109 (1.142 Kg/m)	
2551 (0.357kg/m)		12198 (0.493 Kg/m)	
2552 (0.380kg/m)		12199 (0.600 Kg/m)	
2553 (0.425kg/m)		12197 (0.464 Kg/m)	
		12876 (0.300 Kg/m)	

## 100MM UMBRELLA SLIDING DOORS & WINDOWS

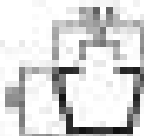
Sec. No.	PROFILE	Sec. No.	PROFILE
11261 (1.217 Kg/m)		09201 (0.500Kg/m)	
11262 (1.597 Kg/m)		12204 (0.541Kg/m)	
11263 (0.681 Kg/m)			
12390 (1.070Kg/m)			
12033 (0.784 Kg/m)			
09041 (0.657 Kg/m)			
12032 (0.673 Kg/m)			

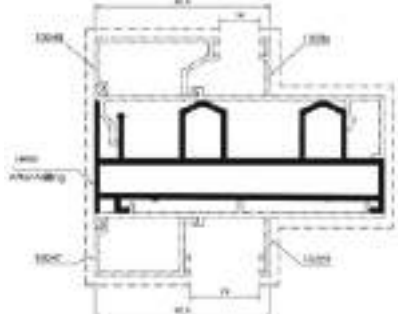
## 100MM BOX UMBRELLA SLIDING DOORS & WINDOWS

Sec. No.	PROFILE	Sec. No.	PROFILE
14006 (1.742 kg/m)		08128 (0.974 kg/m)	
14005 (1.396 kg/m)		08127 (0.957 kg/m)	
12617 (0.974 kg/m)		09931 (0.826 kg/m)	
12616 (0.957 kg/m)		08126 (1.011 kg/m)	
10010 (0.826 kg/m)		21274 (0.353 kg/m)	
12669 (0.826 kg/m)		10048 (0.395 kg/m)	
12095 (0.523 kg/m)		10486 (0.300 kg/m)	
11534 (0.595 kg/m)		14006 Assembly	
10728 (0.375 kg/m)			





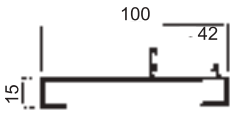
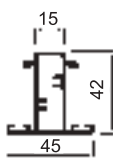
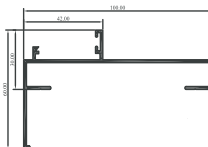
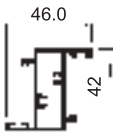
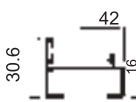
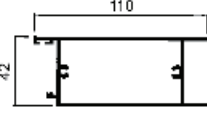
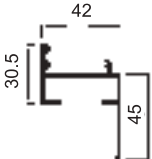
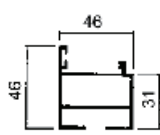
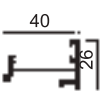
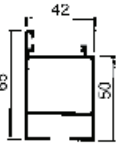
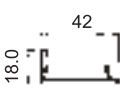
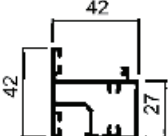
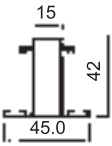
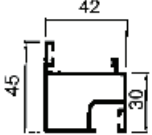
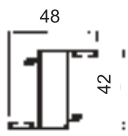
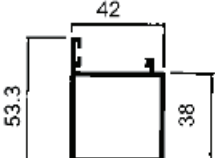

## 105MM SLIDING UMBRELLA INSIDE FLYSCREEN PROFILES

Sec. No.	PROFILE	Sec. No.	PROFILE
13010 (2.203 Kg/m)	<p>10.5 CM Sliding Bottom L / H</p>	13009 (1.678 Kg/m)	<p>10.5 CM Sliding Top L / H</p>
13011 (0.979 Kg/m)		13012 (1.019 Kg/m)	
13013 (1.328 Kg/m)		10485 (0.852 Kg/m)	<p>10485 (0.282KG./M)</p>
10371 (0.298 Kg/m)		12745 (0.457 Kg/m)	
10487 (0.937 Kg/m)	<p>11321 (0.251 Kg/m)</p>	10492 (0.646 Kg/m)	
10969 (0.332 Kg/m)			

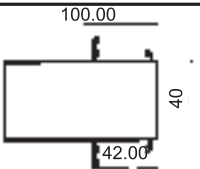

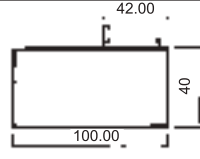
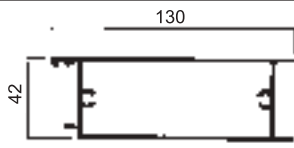
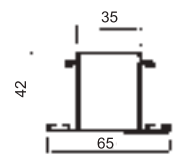
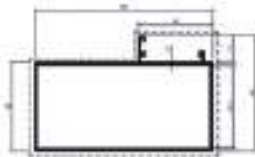
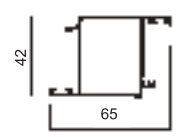

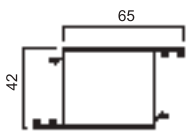
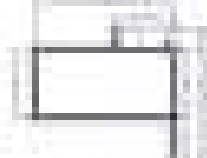
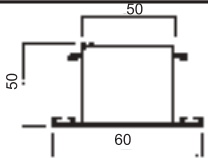
## 42MM HINGED DOOR & WINDOW

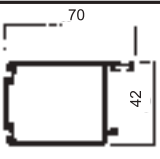
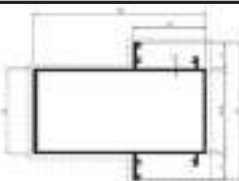
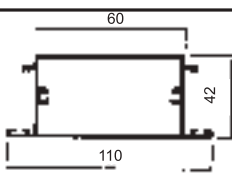
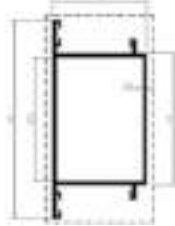
Sec. No.	PROFILE	Sec. No.	PROFILE
10772 (0.800 Kg/m)		12046SC (0.812 Kg/m)	
10266 (0.847 Kg/m)		12047SC (0.812 Kg/m)	
09057 (0.525 Kg/m)		12441 (1.5 Kg/m)	
09210 (0.598 Kg/m)		9912 (0.727 Kg/m)	
09269 (0.445 Kg/m)		9912B (0.901 Kg/m)	
11057 (0.310 Kg/m)		15161 (0.771 Kg/m)	
12047 (0.700 Kg/m)		15161R (0.771 Kg/m)	
12046 (0.700 Kg/m)		12535 (0.753 Kg/m)	

## 42MM HINGED DOOR & WINDOW

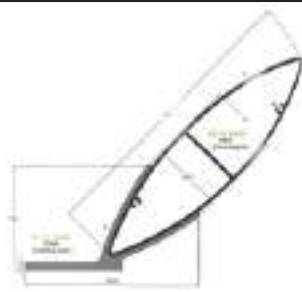
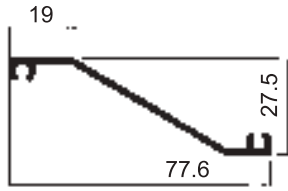
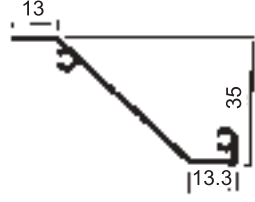
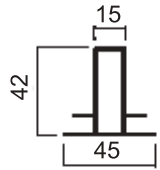
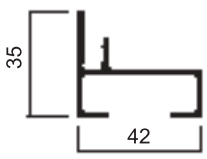
Sec. No.	PROFILE	Sec. No.	PROFILE
12540 (1.539 Kg/m)		9056 (0.228 Kg/m)	
12893 (1.340 Kg/m)		12797 (1.950 Kg/m)	
12051 (0.842 Kg/m)		13035 (1.477 kg/m)	
12048 (0.842 Kg/m)		09055 (2.500 kg/m)	
12042 (1.20 Kg/m)		14637 (1.619 kg/m)	
12043 (1.20 Kg/m)		8203 (0.858 kg/m)	
12059 (1.25 Kg/m)		13036 (1.609 kg/m)	
12156 (1.90 Kg/m)		12541 (1.104 kg/m)	

## LOUVERS, AMPLIMESH & JOINT FLOOR

Sec. No.	PROFILE	Sec. No.	PROFILE
4630 (0.952 Kg/m)	<b>LOUVERS</b> 	Louver Big 	
09153 (0.449 Kg/m)		09029 (0.400 Kg/m)	
12730 (0.637 Kg/m)		9226 (0.566 Kg/m)	
71605 (1.139 kg/m)	<b>JOINT FLOOR</b> 	10077 (0.288 kg/m)	
09006 (0.755 kg/m)			

## 45MM HINGED PROFILES



Sec. No.	PROFILE	Sec. No.	PROFILE
12983 (0.828 Kg/m)		12984 (0.998 Kg/m)	
10462 (1.319 Kg/m)		13155 (1.598 Kg/m)	
13906 (1.470 Kg/m)		13677 (1.670 Kg/m)	
13133 (1.911 Kg/m)		12987 (1.029 Kg/m)	
13005 (1.200 Kg/m)		13449 (1.616 Kg/m)	
12986 (1.114 Kg/m)		10463 (0.933 Kg/m)	

## 45MM HINGED PROFILES



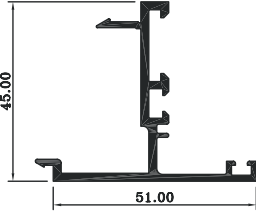

Sec. No.	PROFILE	Sec. No.	PROFILE
13126 (1.474 Kg/m)		13006 (1.682 Kg/m)	
13237 (1.291 Kg/m)		13163 (1.477 Kg/m)	
10463 (0.933 Kg/m)		13466 (1.715 Kg/m)	
10765 (0.473 Kg/m)			

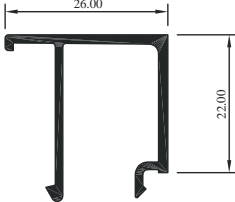
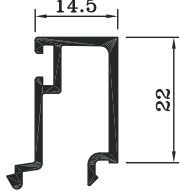
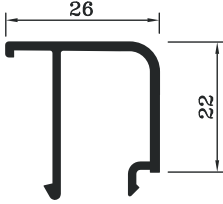
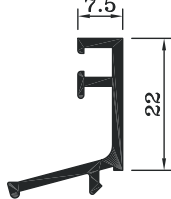
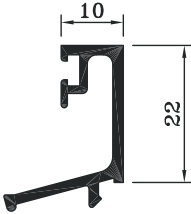



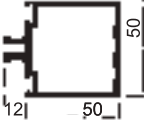
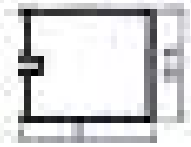
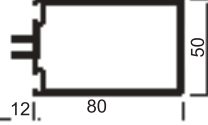
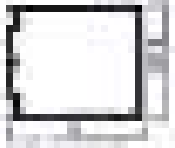
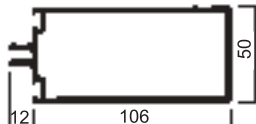
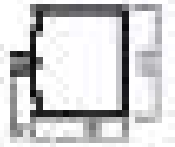
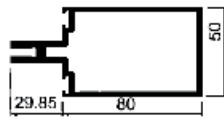

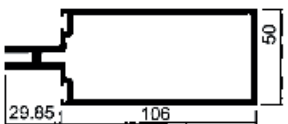

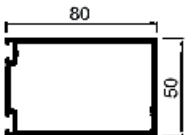
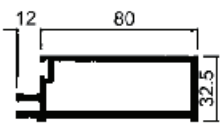
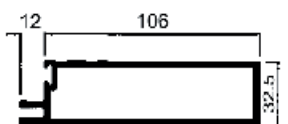





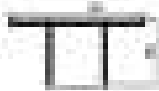



## 45MM HINGED PROFILES

Sec. No.	PROFILE	Sec. No.	PROFILE
10692 (0.706 Kg/m)		09888 (0.175 Kg/m)	
10371 (0.298 Kg/m)		10377 (0.282 Kg/m)	
1957 (0.292 Kg/m)		11321 (0.251 Kg/m)	
10464 (0.271 Kg/m)			

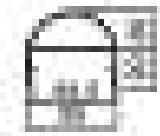

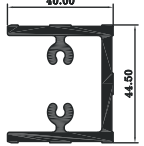

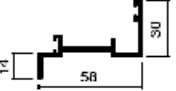

## CURTAIN WALL

Sec. No.	PROFILE	Sec. No.	PROFILE
13795 (1.485 Kg/m)		15122 (2.00 Kg/m)	
13794 (1.976 Kg/m)		15123 (1.935 Kg/m)	
13940 (2.387 Kg/m)		15124 (1.883 Kg/m)	
13794 Big Nozzle (2.362 Kg/m)		15125 (2.113 Kg/m)	
13940 Big Nozzle (2.387 Kg/m)		15126 (2.314 Kg/m)	
13794 Without Nozzle (2.387 Kg/m)			
15125 (1.732 Kg/m)			
15126 (2.107 Kg/m)			

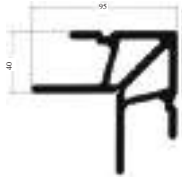
## CURTAIN WALL

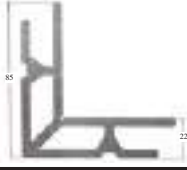
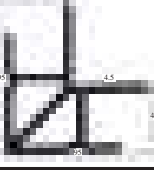
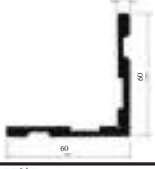
Sec. No.	PROFILE	Sec. No.	PROFILE
13213 (1.226 Kg/m)		13213 D (1.323 Kg/m)	
11388 (4.38 Kg/m)		11272 (4.655 Kg/m)	
11472 (3.65 Kg/m)		11872 (1.364 Kg/m)	
11525 (1.337 Kg/m)		12088 (0.510 Kg/m)	
11069 (1.278 Kg/m)		10529 (0.216 Kg/m)	
11359-Out (1.4 Kg/m)		15128 (1.12 Kg/m)	
15129 (1.668 Kg/m)		12089 (0.600 Kg/m)	
11539-In (1.503 Kg/m)		12090 (0.410 Kg/m)	
10744 (0.752 Kg/m)		15127 (0.600 Kg/m)	

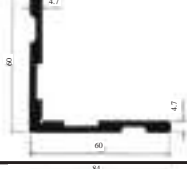
## CORNER CLEAT PROFILES

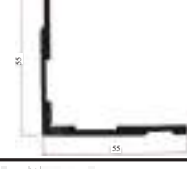
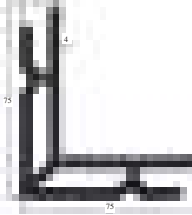
Sec. No.	PROFILE	Sec. No.	PROFILE
12865 (4.739 Kg/m)		81523 (4.572 Kg/m)	
81522 (3.970Kg/m)		81524 (4.751 Kg/m)	
09365 (1.280 Kg/m)		12860 (4.416 Kg/m)	
09458 (1.768Kg/m)		10296 (4.312 Kg/m)	
10682 (1.133 Kg/m)			
09882 (3.384 Kg/m)			
09624 (0.809 Kg/m)			
81521 (2.976 Kg/m)			









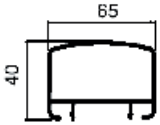

## BALUSTRADES

Sec. No.	PROFILE	Sec. No.	PROFILE
12164 (1.570KG./M.)		12254 (0.495KG./M.)	
		12085 (0.311KG./M.)	
09332 (0.410KG./M.)			
12066 (0.770KG./M.)			
12064 (0.881KG./M.)			
12014 (0.670KG./M.)			
12003 (0.496KG./M.)			
12161 (0.430KG./M.)			



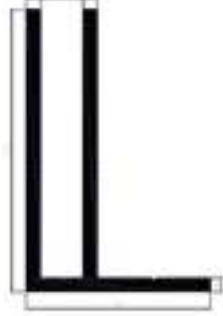
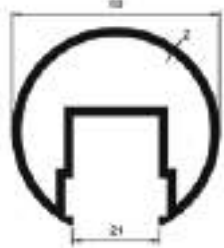



## BALUSTRADES

Sec. No.	PROFILE	Sec. No.	PROFILE
12098 (1.060 Kg/m)		5160 (1.301 Kg/m)	
09015 (0.444 Kg/m)		10216 (0.690 Kg/m)	
09014 (0.300 Kg/m)		10217 (0.552 Kg/m)	
1751 (2.100 Kg/m)		2886 (4.955 Kg/m)	
81244 (1.088 Kg/m)		2439 (0.626 Kg/m)	
		3111 (0.241 Kg/m)	

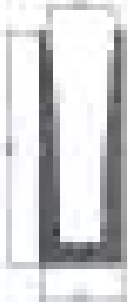
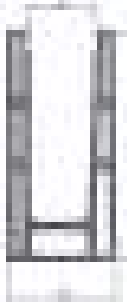
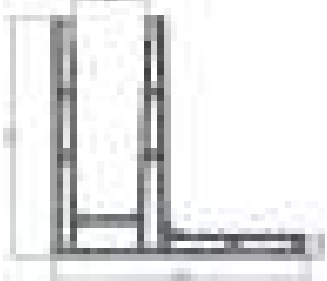
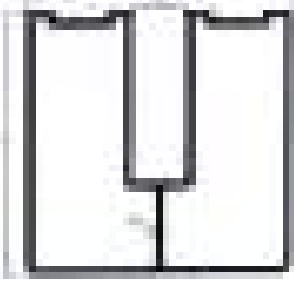

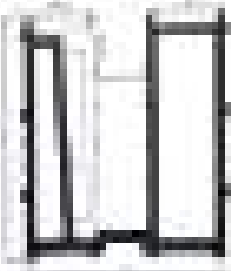
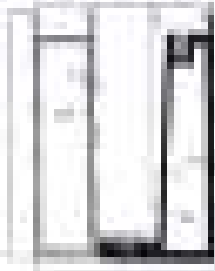
## BALUSTRADES (BOTTOM HANDRAIL PROFILES)

Sec. No.	PROFILE	Sec. No.	PROFILE
10215 (6.707 Kg/m)		20231 (6.438 Kg/m)	
20235 (8.182 Kg/m)		5685 (3.893 Kg/m)	
2438 (1.639 Kg/m)		5518 (5.192 Kg/m)	
5644 (4.235 Kg/m)		5406 (2.776 Kg/m)	
2570 (1.614 Kg/m)		2328 (1.467 Kg/m)	

## 100MM F TYPE BALUSTRADE

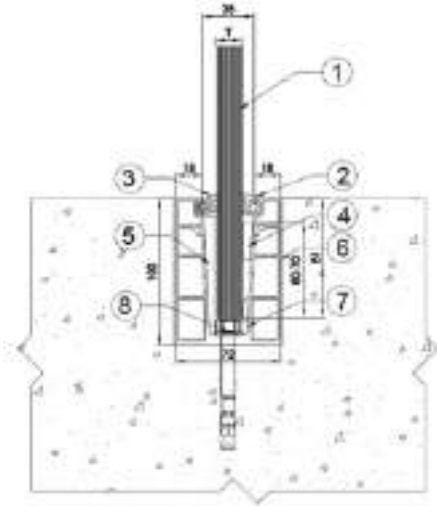
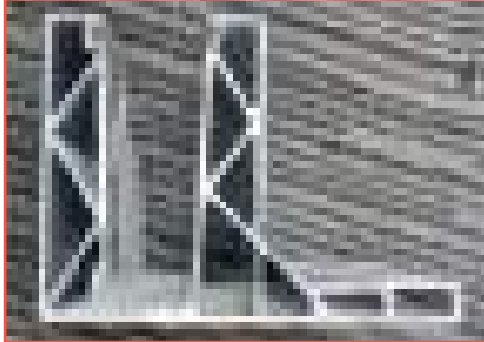

### Load Specification

Uniformly Distributed Load	1.5 kN/M
Line Load	1.0 kN/M
Piont Load	0.89 kN
Glass Thickness	8 - 21.52 MM

### Legends

1. Glass	5. Glass Support : <i>Material</i> - ABS Polymade
2. Inner Gasket : <i>Material</i> - EPDM	6. Profile : Aluminium Profile
3. Outer Gasket : <i>As Per Glass Thickness</i>	7. Expansion Bolt By Others
4. Wedge : : <i>Material</i> - ABS Polymade	8. LED Lighting ( <i>Optional</i> )

*Note* : These loads are for the Aluminium Profiles The System loads will depend on the glass thickeness and concrete quality anchor type, edge distance etc.

## 100MM U TYPE BALUSTRADE

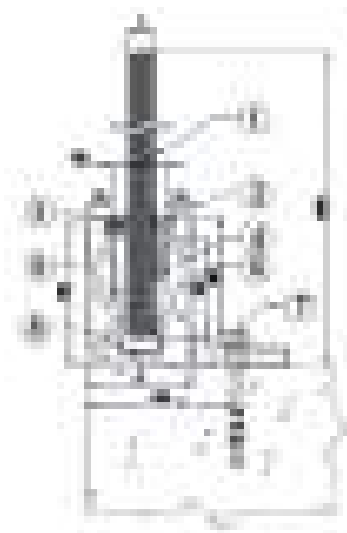

### Load Specification

Uniformly Distributed Load	1.5 kN/M
Line Load	1.0 kN/M
Piont Load	0.89 kN
Glass Thickness	8 - 21.6 MM

### Legends

1. Glass	5. Glass Support : <i>Material</i> - ABS Polymade
2. Inner Gasket : <i>Material</i> - EPDM	6. Profile : Aluminium Profile
3. Outer Gasket : <i>As Per Glass Thickness</i>	7. Expansion Bolt By Others
4. Wedge : : <i>Material</i> - ABS Polymade	8. LED Lighting ( <i>Optional</i> )



## 120MM F TYPE BALUSTRADE

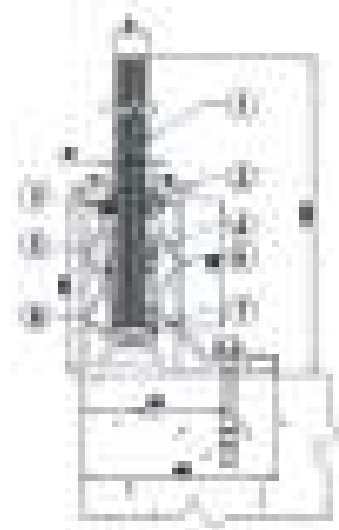
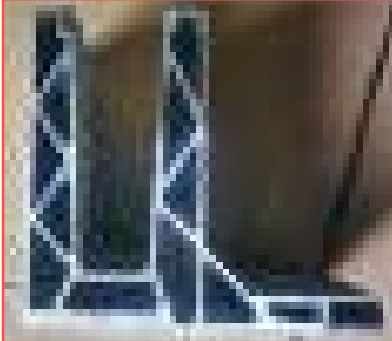

### Load Specification

Uniformly Distributed Load	1.5 kN/M
Line Load	1.0 kN/M
Piont Load	0.89 kN
Glass Thickness	12 - 21.52MM

### Legends

1. Glass	5. Glass Support : <i>Material</i> - ABS Polymade
2. Inner Gasket : <i>Material</i> - EPDM	6. Profile : Aluminium Profile
3. Outer Gasket : <i>As Per Glass Thickness</i>	7. Expansion Bolt By Others
4. Wedge : : <i>Material</i> - ABS Polymade	8. LED Lighting ( <i>Optional</i> )

*Note* : These loads are for the Aluminium Profiles The System loads will depend on the glass thickness and concrete quality anchor type, edge distance etc.

## 120MM U TYPE BALUSTRADE

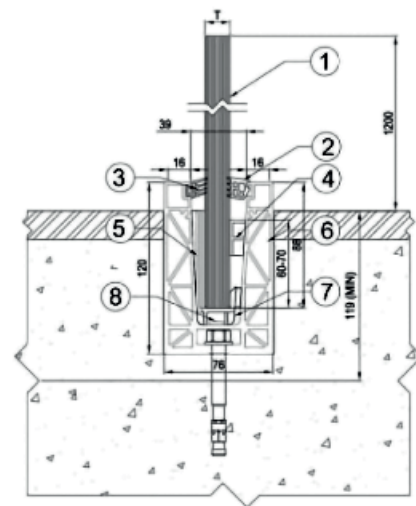

### Load Specification

Uniformly Distributed Load	1.5 kN/M
Line Load	1.0 kN/M
Piont Load	0.89 kN
Glass Thickness	12 - 21.52MM







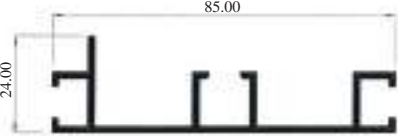

### Legends

1. Glass	5. Glass Support : <i>Material</i> - ABS Polymade
2. Inner Gasket : <i>Material</i> - EPDM	6. Profile : Aluminium Profile
3. Outer Gasket : <i>As Per Glass Thickness</i>	7. Expansion Bolt By Others
4. Wedge : : <i>Material</i> - ABS Polymade	8. LED Lighting ( <i>Optional</i> )



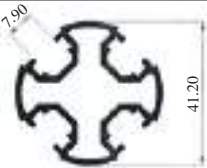

## KITCHEN CABINET PROFILES

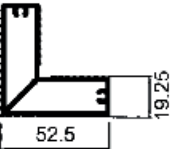
Sec. No.	PROFILE	Sec. No.	PROFILE
13084 (0.424 kg/m)		91962 (0.305 kg/m)	
13085 (0.489 kg/m)		83466 (0.457 kg/m)	
13086 (0.489 kg/m)		83465 (0.326 kg/m)	
10170A (0.120 kg/m)		15152 (0.400 kg/m)	
08219 (0.710 kg/m)		13088 (0.490 kg/m)	
06192 (0.482 kg/m)		84197 (0.280 kg/m)	
06193 (0.196 kg/m)		84196 (0.249 Kg/m)	
20245A (0.58 kg/m)		84195 (0.272 Kg/m)	

## SHOWCASE PROFILE

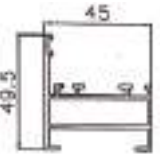
Sec. No.	PROFILE	Sec. No.	PROFILE
5124 (0.410 kg/m)		5120 (0.722 kg/m)	
5121 (0.314 kg/m)			
5122 (0.274 kg/m)			
08258 (0.809 kg/m)			
5123 (0.203 kg/m)			
5118 (0.505 kg/m)			
5119 (0.542 kg/m)			
12873 (1.325 kg/m)			

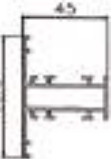
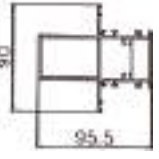
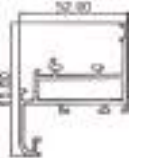
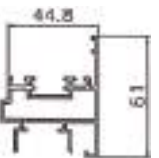
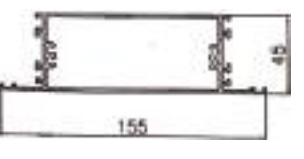
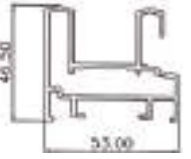
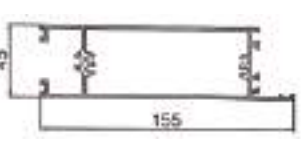
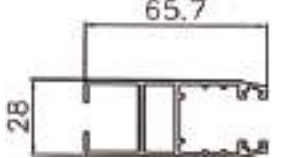
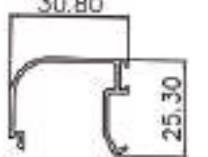
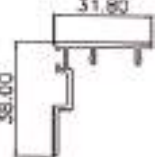
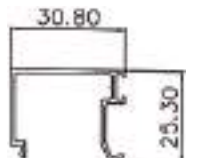
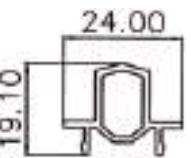
## ALLCO 5 SYSTEM (1.5MM + 1.8MM)

Sec. No.	PROFILE	Page No.	Sec. No.	PROFILE
L (1.5mm = 0.800 kg/m) (1.8mm = 0.950 kg/m)			INVERTOK (1.5mm = 0.75 kg/m)	
T (1.5mm = 0.9 kg/m) (1.8mm = 1.15 kg/m)			T-STRC (1.5mm = 1.700 kg/m)	
Z (1.5mm = 0.95 kg/m) (1.8mm = 1.2 kg/m)			T-COMP (1.5mm = 0.95 kg/m) (1.8mm = 1.15 kg/m)	
FASHA (1.5mm = 1.6 kg/m) (1.8mm = 2.10 kg/m)			SLIDING EXTERNAL (1.5mm = 1.20 kg/m) (1.8mm = 1.350 kg/m)	
ZOCOLOW (1.5mm = 1.8 kg/m) (1.8mm = 2.3 kg/m)			SLIDING INTERNAL SINGLE (1.5mm = 0.95 kg/m) (1.8mm = 1 kg/m)	
OVAL F SINGLE (1.5mm = 0.3 kg/m) (1.8mm = 0.35 kg/m)			SLIDING CLIP (0.400 kg/m)	
FLAT FERMA (1.5mm = 0.3 kg/m) (1.8mm = 0.35 kg/m)			SLIDING CONNECTOR (0.040 kg/m)	
FLAT FERMA DOUBLE (0.300 kg/m)			SLIDING INTERNAL DOUBLE (1.010 kg/m)	

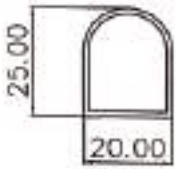
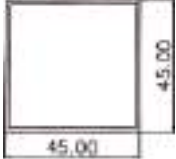
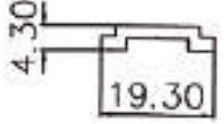
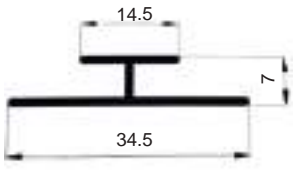

## ALLCO 5 SYSTEM (1.5MM + 1.8MM)

Sec. No.	PROFILE	
GRILL (0.400kg/m)		
BOX 45X45 (0.90kg/m)		
ASTNA (0.025kg/m)		
73407		

## 55MM HINGED THERMAL BREAK AREXCO







Sec. No.	PROFILE	Sec. No.	PROFILE
6001 (1.111 kg/m)	<p>6001 WEIGHT : 1.111 Kg/m</p>	6002 (1.337 kg/m)	<p>6002 WEIGHT : 1.337 Kg/m</p>
6003 (1.162 kg/m)	<p>6003 WEIGHT : 1.162 Kg/m</p>	6006 (1.510 kg/m)	<p>6006 WEIGHT : 1.510 Kg/m</p>
6005 (1.251 kg/m)	<p>6005 WEIGHT : 1.251 Kg/m</p>	6004 (1.349 kg/m)	<p>6004 WEIGHT : 1.349 Kg/m</p>

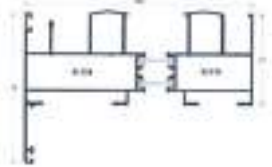

## 55MM HINGED THERMAL BREAK AREXCO

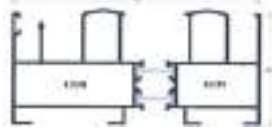
Sec. No.	PROFILE	Sec. No.	PROFILE
6008 (1.496 kg/m)		6007 (0.872 kg/m)	
6016 (0.918 kg/m)		6015 (1.589 kg/m)	
6014 (1.694 kg/m)		6009 (0.840 kg/m)	
71603 (0.221 kg/m)		71606 (1.042 kg/m)	

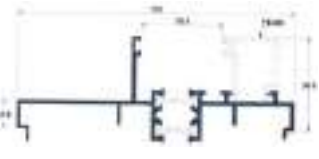
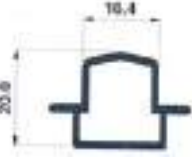
## 105MM HINGED THERMAL BREAK AREXCO

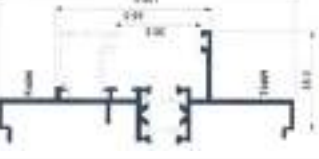
Sec. No.	PROFILE	Sec. No.	PROFILE
5007 (2.126 kg/m)		71607 (0.350 kg/m)	
5002 (2.264 kg/m)			
5003 (1.284 kg/m)			
5009 (1.078 kg/m)			
81531 (0.335 kg/m)			
81530 (0.395 kg/m)			
5004 (1.095 kg/m)			

## 120MM HINGED THERMAL BREAK AREXCO

Sec. No.	PROFILE	Sec. No.	PROFILE
5015 (2.592 kg/m)		5014 (1.173 kg/m)	
5016 (2.441 kg/m)		5017 (1.149 kg/m)	
73256 (0.399 kg/m)		5013 (1.521 kg/m)	
73255 (0.297 kg/m)			
83654 (0.420 kg/m)			
83655 (0.376 kg/m)			

# KATCO

GLASS



**GLASS**

PACKING & LOADING

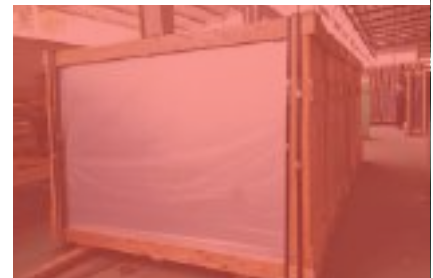

[www.katco.ae](http://www.katco.ae)

[www.katco.ae](http://www.katco.ae)



## GLASS

WE DEAL WITH ALL TYPES OF GLASSES IN ALL SIZES AND ALL THICKNESS FROM USA, BELGIUM, CHINA, UAE. etc...

- ▶ Clear Float Glass in 3mm, 4mm, 5mm, 6mm, 8mm, 10mm, 12mm, 15mm and 19mm
- ▶ Reflective Glass all colors (Blue, Green, Bronze, Grey, Gold, Pink, Silver, etc)
- ▶ Tinted Glass (Blue, Green, Bronze, Grey etc)
- ▶ Ultra Clear Mirrors, antique mirrors, Colored Mirrors (Black, Grey, Bronze, Gold, etc) & Clear Mirrors in 3mm, 4mm, 5mm, 6mm and 8mm
- ▶ Laminated glass - (6.38mm, 8.38mm etc)
- ▶ Fire Rated Glass & wired glass (clear & pattern) available in different colors
- ▶ Ultra Clear Glass (Crystal Clear Glass) available in 4mm, 5mm, 6mm, 8mm, 10mm, 12mm, 15mm and 19mm
- ▶ Ramly or Figure Glass (Clear, Bronze, etc) and Low E glass-6mm thickness

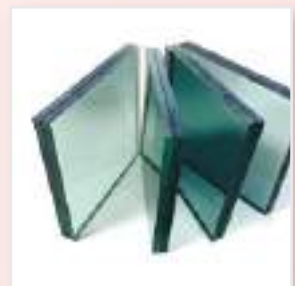
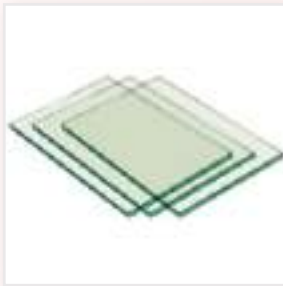

## FOLDING DOOR SYSTEM | Complete Line Of Light & Heavy System

TOPFLEX & LIGHTFLEX are the complete Aluminium folding system of Master. It is a complete program that covers all usage needs.

### WHY FOLDING DOORS

1. Wide Range Of The Uses & Very Customisable
2. Large Amount Of Natural Height
3. Take Up Less Space Than Other Doors
4. Particularly Modern Addition

### TOPFLEX Thermal Break Aluminium Folding Door System



With TOPFLEX System it is possible to make large opening with dimension that can reach up to 3500 MM in Width. Maximum capacity is 120 KG per sash. Suitable for 20 MM to 50 MM Glass Thickness

**Aluminium** Thermal Break

**Security** Security Lock Applicable

**Operation** Manual Operation

**Opening** Type Up to 20 Opening There

**Colours** Wide Range Of Colors

### TOPFLEX Non - Thermal Break Aluminium Folding Door System

With LIGHTFLEX System it is possible to make opening with dimension that can reach up to 2500 MM in height & 200 MM Width. Maximum capacity is 60 KG per sash. Suitable for 8 MM to 24 MM Glass Thickness

**Aluminium** Thermal Break

**Security** Security Lock Applicable

**Operation** Manual Operation

**Opening** Type Up to 20 Opening There

**Colours** Wide Range Of Colors





## Accessories - Handles



H/D Door Handle  
KMA-1



Srew Door Handle  
KMA-2



Pad Door Handle  
KMA-3



Pipe Door Handle  
KMA-4



Sliding Volga Handle  
KMA-5



Square Sliding Handle  
KMA-6



D Door Handle - Big  
KMA-7



D Door Handle - Small  
KMA-8



Cremona Handle  
KMA-9



C/W Handle - Big  
KMA-10



C/W Handle - Small  
KMA-11



L/R Handle  
KMA-12



Sliding American Handle  
KMA-13



Sliding Spring Handle  
KMA-14



Sliding Kick Handle  
Without Key I KMA-15



Sliding Kick Handle  
With Key I KMA-16



Sliding Japan Single  
KMA-17



Sliding Japan Double  
KMA-18

## Accessories - Hinges



42 Hinge Big 60mm  
KMA-20



42 Hinge Small 40mm  
KMA-21



45 Hinge 2 Leaf  
KMA-22



45 Hinge 3 Leaf  
KMA-23



H/D Hinge 2 Leaf  
KMA-24



H/D Hinge 3 Leaf  
KMA-25



Canceled Tower Bolt  
KMA-26



Finger Catch  
KMA-27



Side Arm Normal  
KMA-28



Stay Arm 8-28  
KMA-29



Telescopic Sty Arm  
KMA-30



Tower Bolt O/Side &  
ALDROP 2-28  
KMA-31



Tower Bolt T/B  
KMA-32



Sliding Connector  
KMA-211



Hinge Connector  
KMA-212



Cross Connector  
KMA-213



T - Connector  
KMA-214

## Accessories - Locks



20MM Latch Lock  
KMA-33



20MM Latch Lock Knob  
KMA-34



20MM Roller Lock  
KMA-35



30MM Latch Lock  
KMA-36



30MM Roller Lock  
KMA-37



Hook Lock  
KMA-38



Indicator Lock  
KMA-39

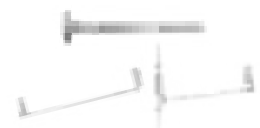

Panic Lock System  
KMA-40



Strike Plate & Cylinder  
Cover  
KMA-41



Cylinder 55,60,70,80,90MM  
KMA-42



Cylinder Unequal 80MM  
KMA-43



Cylinder Knob 55,60,70  
KMA-44



Cylinder 54 Oval  
KMA-45



Drawer Lock  
KMA-46



T Lock  
KMA-226

## Accessories - Roller

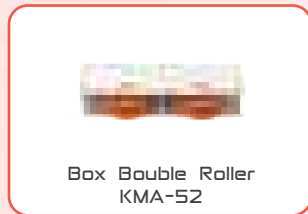
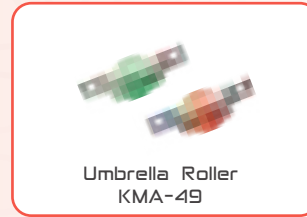
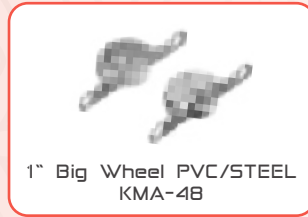

## Double Glass Accessories

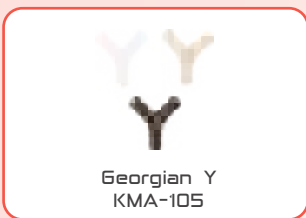
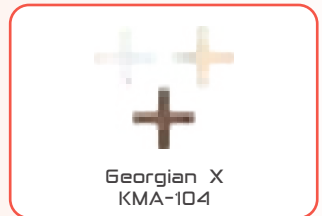
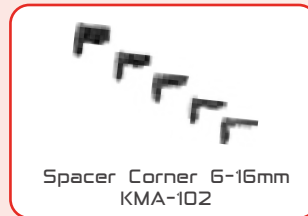
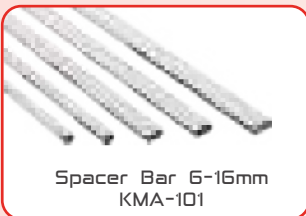

## Aluminium Accessories

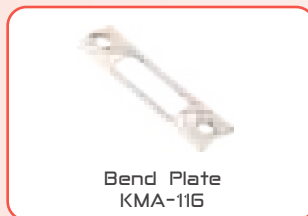
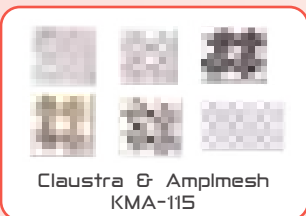



Silicon Tube All Color  
KMA-119W,C,BK,B6



Vertical Spring  
KMA-120



Silicon Sausage All Colors  
KMA-121W,C,BK,B6



Fly Screen Roll  
3-6FT/aluminum, fiber  
KMA-122 3f-6f



Top Door Closer  
KMA-123



Floor Door Closer  
KMA-124



Floor Door Closer  
Accessories  
KMA-125



Staircase Shoe  
30x30,35x35,40x40  
KMA-126-30,35,40

## Tools



Silicon Gun Small  
KMA-127



Silicon Gun Big  
KMA-128



Rivet Gun Manual  
KMA-129



Rivet Gun By Air  
KMA-130



Plastic hammer  
KMA-131



Fixing roller for fly screen  
KMA-132



Bohle glass cutter  
KMA-133



Bohle Round Glass Cutter  
KMA-134



Glass Lifter 3H  
KMA-135



Glass Lifter 2H  
KMA-136



Glass Right Angle  
KMA-137



Measuring Tape  
3,5,7,5,10Mter  
KMA-138-3,5,7,5,10



Cutting Disk  
250,300,320,350,400,420,  
450,500,550mm  
KMA-139-250-550



Knife & Spare Knife  
KMA-140

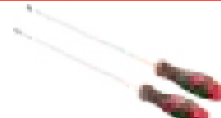

Screw Driver Flat  
Head/Star Head All Size  
KMA-141



File Flat/Round All Size  
KMA-142



H5 Drill Bit All Sizes  
KMA-143



Freezing Bit (4,6,8mm)  
Short & Long  
KMA-144

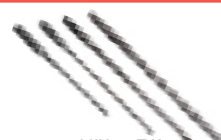

Hilty Bit  
(6,8,10,12mm)  
KMA-145

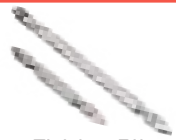

Tighter Bit  
Flat Head/Star head  
KMA-146



Sheet Cutter Plier  
KMA-147



Hack Saw Frame  
with Blade  
KMA-148



Try Square Angle  
8",10",12"  
KMA-149



SS Scraper  
KMA-150



Allen Key Set  
KMA-151



Sprite Level  
KMA-152



Air Drill  
KMA-153



Plier  
KMA-154

## Kitchen Items



Kitchen Corner 2 Way  
KMA-155



Kitchen Corner 3 Way  
KMA-156



Kitchen Corner 4 Way  
KMA-157



Kitchen Shutter Corner  
KMA-158



Kitchen Degree Corner  
KMA-159



Kitchen Hinges  
KMA-160



Kitchen Ginges Hydraulic  
KMA-161



Kitchen Drawer Normal  
KMA-162



Kitchen Drawer Hydraulic  
KMA-163



Kitchen SS T Bar Handle  
KMA-164



Hydraulic Stay  
KMA-165

## Plastic Items



Screw Hole Cover  
KMA-206



Water Drain Cover/Cap  
KMA-207



Shutter Cover/Cap  
KMA-208



PVC Fly Screen Handle  
KMA-209



PVC Chim Packing  
1mm,2mm,3mm,4mm,5mm  
KMA-229



PVC Bottom Water Cap  
KMA-230

## Screws & Rivets

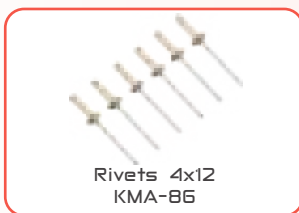
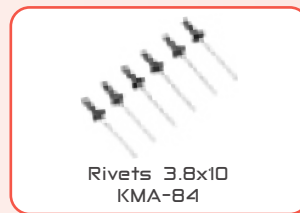
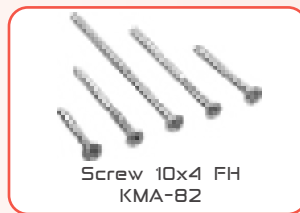
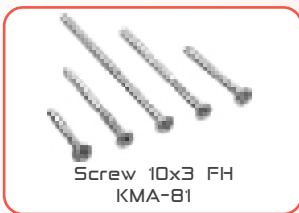
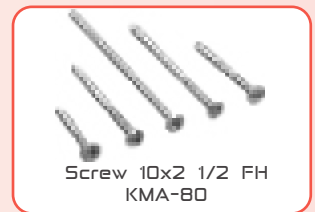
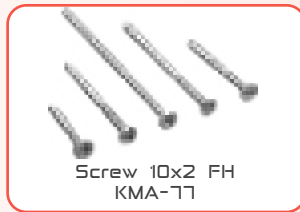
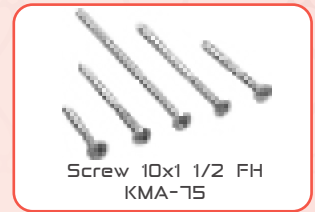

## Patch Fitting



Top Patch  
KMA-166



Bottom Patch  
KMA-167



Center Lock  
KMA-168



Corner Lock  
KMA-169



L-Patch W/O Pivot  
KMA-170



L-Patch With Pivot  
KMA-171



Round Type Glass Lock  
KMA-172



Top Pivot  
KMA-173



Strike Box  
KMA-174



Wall Mount With Pivot  
KMA-175



Double Strike Box  
KMA-176



SS Straight Handle  
KMA-177



SS Shower Door Handle  
KMA-178



SS D&C Handle  
KMA-179



SS Lip Seal Side Soft  
KMA-180



SS Lip Seal Center Soft  
KMA-181



SS Lip Seal Bubble Type  
KMA-182



SS Lip Seal Magnetic Type  
KMA-183



SS Glass Spacer  
KMA-184



SS Glass Holder  
KMA-185



SS-304 Hydraulic Patch  
KMA-186



SS Dust Socket  
KMA-187



SS Glass to Glass Hinge For  
Shower (Silver, Black, Gold)  
KMA-188



SS Wall to Glass Hinge For  
Shower (Silver, Black, Gold)  
KMA-189



SS Shower Knob Handle  
(Silver, Black)  
KMA-190



SS Wall to Pipe Connector  
(Silver, Black)  
KMA-191



SS Adjustable Elbow  
(Silver, Black)  
KMA-192



SS Glass to Pipe Connector  
(Silver, Black)  
KMA-193

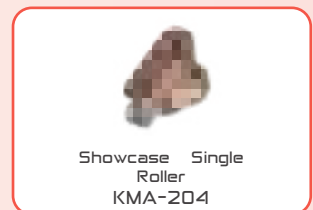
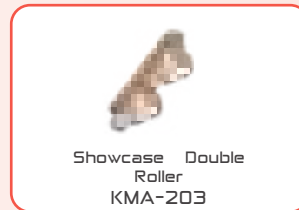
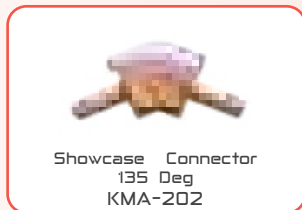
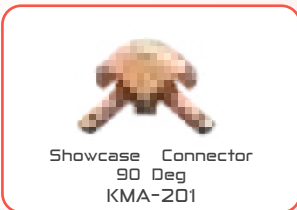
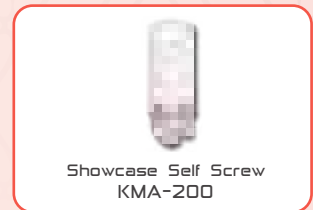
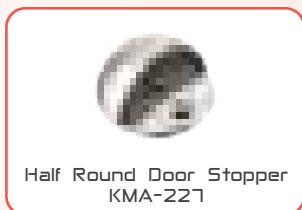

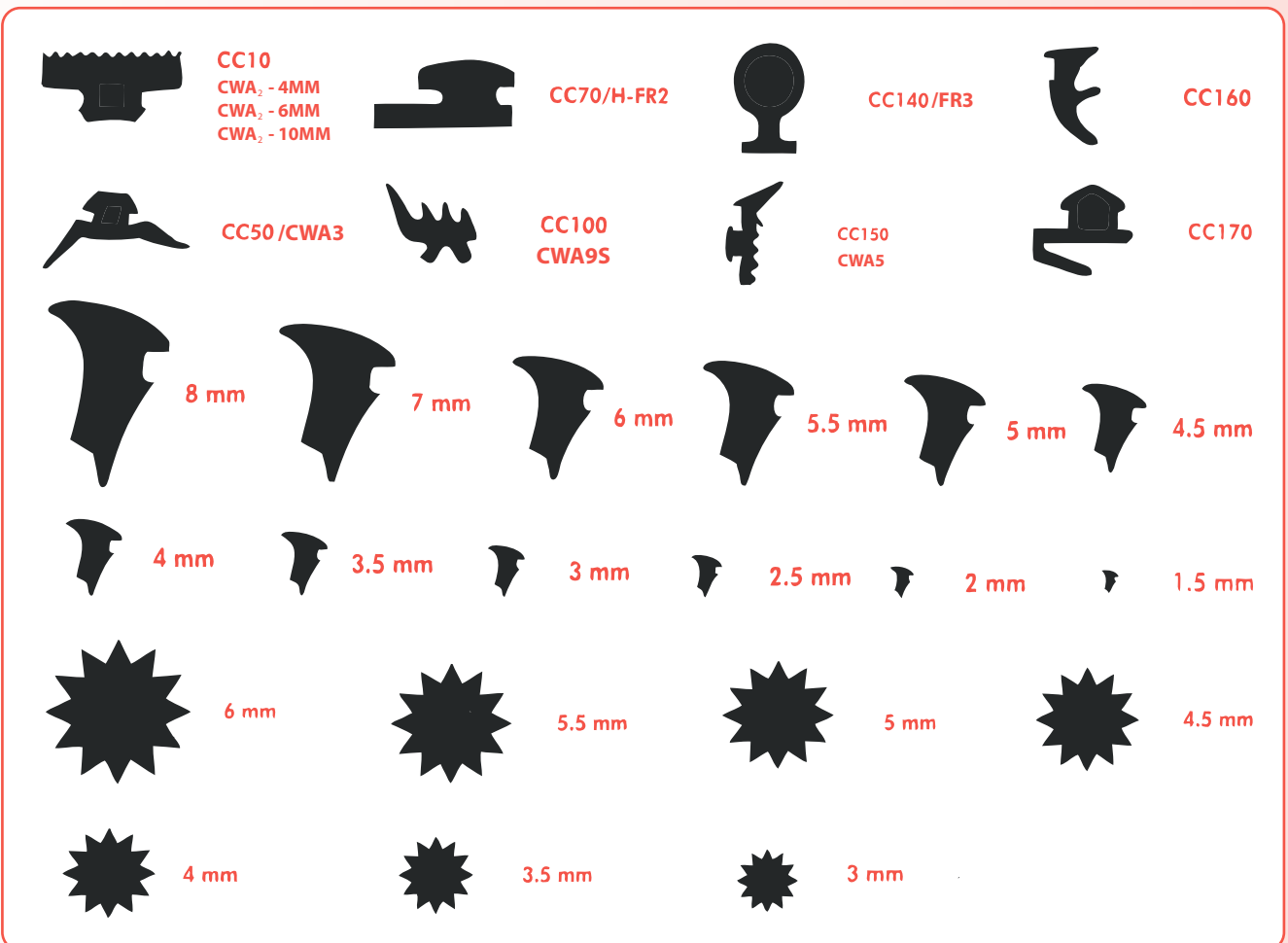

## Rubber Gaskets



## Main Office

 Industrial Area 15, Al Maliha Road  
Sharjah - UAE

 +971 6 539 3349  
+971 6 535 4650

 +971 6 535 4651

 bumosomeh@katco.ae

 mosameh@katco.ae

 info@katco.ae

 www.katco.ae

 +971 54 757 2231



## Branch Offices

### Al Dhaid Branch

 Al Taiba 2 - Al Dhaid  
Sharjah - UAE

 +971 6 568 1311

 branch1@katco.ae

 www.katco.ae

 +971 56 891 0448



### Abu Dhabi Branch

 Mussafah M26  
Abu Dhabi - UAE

 +971 2 445 0919

 adb@katco.ae

 www.katco.ae

 +971 56 608 9793

