

براد اتلانتا للتجارة فمم  
**BARAD ATLANTA TRADING L.L.C.**



# An Ultimate Choice For Your Entire Cold Room Requirements...

## **INDEX**

1.	Company Profile	2 - 3
2.	Locks & Hinges	4 - 13
3.	Pressure Relief Valves	14 - 15
4.	Panel Fastners	16
5.	Lighting & Electrical	17 - 18
6.	Reach in Hardwaare	19 - 21
7.	Food Service Hardware	22 - 24
8.	Sliding & Hinged Doors Accessories	25 - 27
9.	PVC Profiles	28 - 32
10.	Magnetic Gaskets	33
11.	Floor Heating Cables	34 - 35
12.	Truck Box Accessories	36 - 38
13.	PVC Strip Curtain & Rail	39 - 43
14.	Cladding Material	44

Barad Atlanta Trading LLC, Established in early 2010, with its operational base in Sharjah, Near Bin Laden Signal, Ind.Area-11. Barad Atlanta Trad. LLC, offers a wide spectrum of products and superior quality services to the customers. We are mainly focusing to the business area of Refrigeration, Cold Storage, Refrigerated Truck Boxes, Roof and Cladding. We pride ourselves on being able to offer any kind of accessories, spare parts & service to the focused area of business & we are committed to provide highly responsive, customer-focused services.

**The focal points of our business are:**

- ✓ Food Processing Units
- ✓ Meat & Fish Processing Units
- ✓ Supermarkets
- ✓ Dairy Companies
- ✓ Logistics & Distribution companies etc..
- ✓ Fruits & Vegetable Outlets
- ✓ Pharmaceutical Companies
- ✓ Bakeries
- ✓ Ice Cream Plants

**We have wide range of product lines related to:**

- Cold Room - Chiller & Freezers
- Food Services
- Clean Rooms
- Insulated Panels
- Speed Doors
- Refrigerated Truck Boxes
- Kitchen Equipments
- Roofing Sheets
- Sky Lights
- Industrial Doors

**We are the agents and UAE & Middle East Distributor's of major brand products:**

★ **KASON INDUSTRIES, USA**

- Hinges
- Pressure Relief Valves
- Leg Sockets
- Drawer Slides
- LED Light Fixtures
- Latches
- Foot Inserts
- Equipment Legs
- Cabinet Hardware's
- Swing Doors

★ **FLEXTRUDE, UK**

- PVC Strip Curtains
- Anti Insect Strips
- PVC Sheets
- SS Fixing Rails, Plate sets

★ **MIV, ITALY**

- Sliding Door Accessories
- Door Wheels
- Door Handles
- Gaskets



★ **PASTORE & LOMBARDI, ITALY**

Lock Sets  
Meat Hanging Rail  
Partition Accessories

Hinges  
Meat Hooks  
Ceiling Lights

★ **CASTEL ENGINEERING, BELGIUM**

PVC Covings  
PVC Bumper Rails  
PVC Corner Profiles

★ **DANDOORS, DENMARK**

Sliding Door Accessories  
Door Wheels  
Gaskets

Door Handles  
Lock Sets  
Heater Wires

★ **TRICOMP, USA**

Magnetic Gaskets  
Magnetic Strips

**Also Deal With :**

**DANFOSS - DEVI** Floor Heating Cables, **EXTRUFLEX PVC** Strip Curtains, **FERMOD** Sliding Door Accessories & many more...

**Our Values:**

Ethical Business Strategy with Integrity & Loyalty.  
Service Beyond Customer Expectations.

**For more Details:**

You can contact us at the below address & tel. number or visit our website: - [www.albaraduae.com](http://www.albaraduae.com) or mail us at [info@albaraduae.com](mailto:info@albaraduae.com) for you queries.



We're here to Help..



**Barad Atlanta Trad.LLC**

P.O. Box 61975, Ind.Area-11, Sharjah, U.A.E.

T: + 971 6 5443301, F: +971 6 5443302

E: [info@albaraduae.com](mailto:info@albaraduae.com), [sales@albaraduae.com](mailto:sales@albaraduae.com) , W: [www.albaraduae.com](http://www.albaraduae.com)





## Commercial & Refrigeration Hardware

### Cold Rooms:

Chiller & Freezer Door Latches, Hinges, Door Closers, Ventilators, Panel Fastners, Electrical Devices, Light Fixtures, Vinyl Swing Doors

### Reach In:

Commercial Cooler & Freezer Parts

### Food Service:

Commercial Kitchen Equipment Legs, Oven Hardware, Shelving Hardware

We are Committed to your Satisfaction.....



UAE & Middle East Distributor

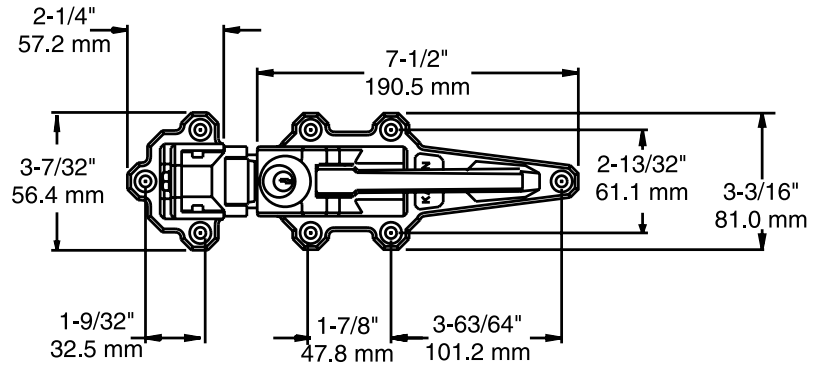

Model No.	Item	Offset
0050S00002	Stationary Cylinder Locking Latch	-1/4" to 1/8" (-6.4 to 3.2 mm)
0050S00008	Stationary Cylinder Locking Latch	Flush to 1/2" (0.0 to 12.7 mm)
0050S00012	Stationary Cylinder Locking Latch	3/4" to 1-1/4" (19.0 to 31.8 mm)
0050S00020	Stationary Cylinder Locking Body	
0050AS0090	Cylinder & Keys for 50S Latch Body	
0048000028	Strike for 0050 Latch	Flush to 1/2" (0.0 to 12.7 mm)
0048000032	Strike for 0050 Latch	3/4" to 1-1/4" (19.0 to 31.8 mm)
0048000034	Strike for 0050 Latch	-1/4" to 1/8" (-6.4 to 3.2 mm)

Cylinder locks may be keyed alike or differently; 50 key changes available; please specify. Two keys are furnished.

Packaging/Weight 1 per carton/ Approx. 7 lb. (3.2kg) per carton.

**0051 CYLINDER LOCKING BRASS LATCH**

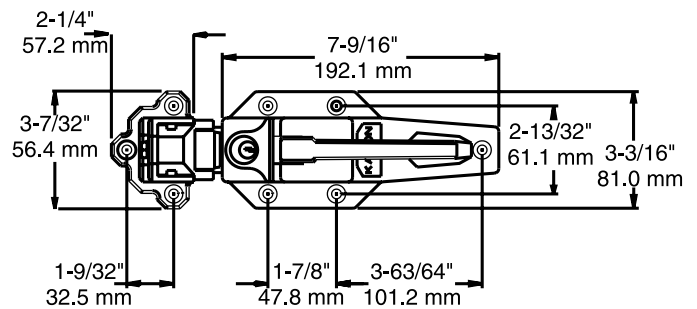

Model No.	Item	Offset
0051S00002	Stationary Cyl. Locking Latch	-1/4" to 1/8" (-6.4 to 3.2 mm)
0051S00008	Stationary Cyl. Locking Latch	Flush to 1/2" (0.0 to 12.7 mm)
0051S00012	Stationary Cyl. Locking Latch	3/4" to 1-1/4" (19.0 to 31.8 mm)
0051S00006	Stationary Cylinder Locking Body	
0050AS0090	Cylinder & Keys for 51S Latch Body	

Packaging/ Weight: 1 per carton. Approx. 6 lb (2.7kg) per carton.

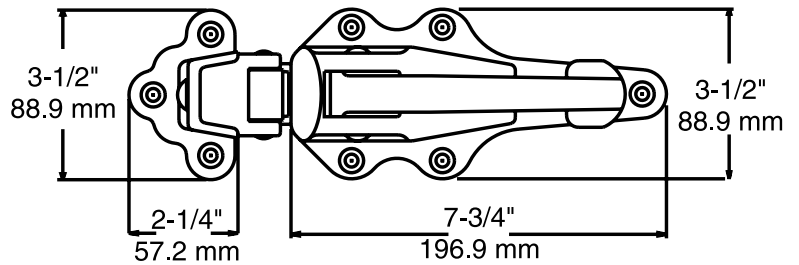

Model No.	Item	Offset
0052000004	Padlocking Latch	-1/8" to 5/16" (-3.2 to 7.9 mm)
0052000012	Padlocking Latch	3/4" to 1-3/8" (19.0 to 34.9 mm)
0052000076	Padlocking Body	
0052000084	Strike	-1/8" to 5/16" (-3.2 to 7.9 mm)
0052000092	Strike	3/4" to 1-3/8" (19.0 to 34.9 mm)

Packaging/ Weight: 1 per carton /Approx. 5-3/4 lb. (2.6kg) per carton.

**0053 IRON PADLOCKING LATCH**

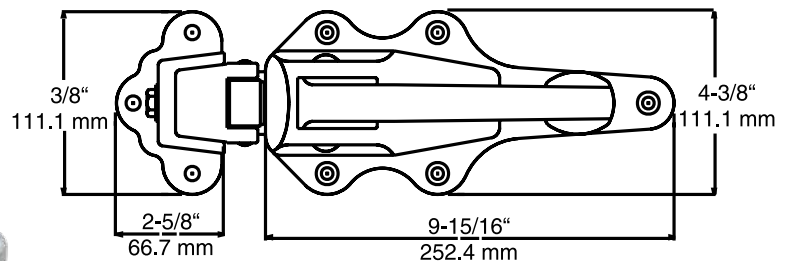

Model No.	Item	Offset
0053000004	Padlocking Latch	-1/4" to 1/8" (-6.4 to 3.2 mm)
0053000008	Padlocking Latch	15/16" to 1-5/8" (23.8 to 41.3 mm)
0053000052	Padlocking Body	
0053000064	Strike	15/16" to 1-5/8" (23.8 to 41.3 mm)

Packaging/ Weight: 1 per carton /Approx. 5-3/4 lb. (2.6kg) per carton.

# 0055 SAFEGUARD® LATCH

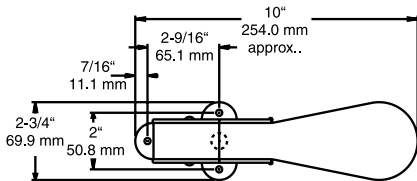
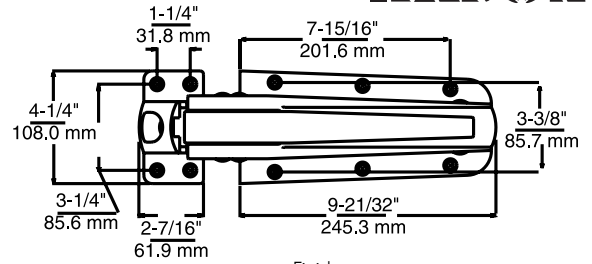

Model No.	Offset	Finish
0055000020	Flush to 3/16" (0.0 to 4.8 mm)	Polished Chrome
0055000024	3/4" to 1-1/8" (19.0 to 28.6 mm)	Polished Chrome
0055000028	1-1/8" to 1-5/8" (28.6 to 41.3 mm)	Polished Chrome
0055000032	1-3/8" to 1-7/8" (34.9 to 47.6 mm)	Polished Chrome
0055000065	Flush to 3/16" (0.0 to 4.8 mm)	Tuffkote
0055000066	3/4" to 1-1/8" (19.0 to 28.6 mm)	Tuffkote
0055000068	1-1/8" to 1-5/8" (28.6 to 41.3 mm)	Tuffkote
5582000004	1-1/8" to 1-5/8" (28.6 to 41.3 mm)	Chrome

No. 0055 bodies and strikes may be ordered separately.

Brushed Chrome and Powder Coat finishes available. Request information.

Packaging / Weight : 1 per carton / Approx. 14 lb. (6.4kg) per carton.

# 0056 SAFEGUARD® LATCH

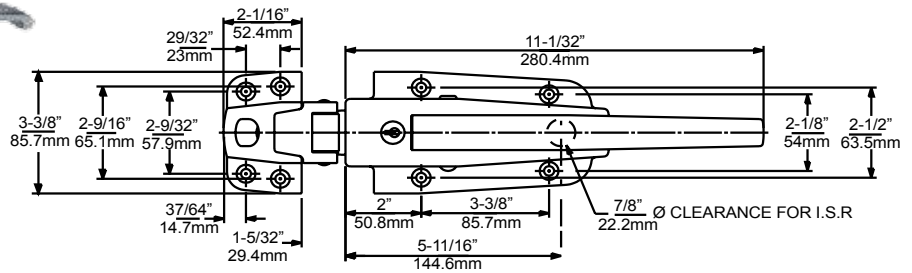

Model No.	Item	Description	Finish
0056CH5020	Cylinder Locking Body	Heavy Spring	Polished Chrome
0056CH6021	Cylinder Locking Body	Heavy Spring	Brushed Chrome
0056CH0086	Cylinder Locking Body	Heavy Spring	Tuffkote
0056CL5020	Cylinder Locking Body	Light Spring	Polished Chrome
0056CL6021	Cylinder Locking Body	Light Spring	Brushed Chrome
0056CL0086	Cylinder Locking Body	Light Spring	Tuffkote
0056CX5020	Cylinder Locking Body	X-Light Spring	Polished Chrome
0056H05020	Padlocking Body	Heavy Spring	Polished Chrome
0056H06021	Padlocking Body	Heavy Spring	Brushed Chrome
0056L05020	Padlocking Body	Light Spring	Polished Chrome
0056L06021	Padlocking Body	Light Spring	Brushed Chrome
0056L00086	Padlocking Body	Light Spring	Tuffkote
0056XL5020	Padlocking Body	X-Light Spring	Polished Chrome
0056XL6020	Padlocking Body	X-Light Spring	Brushed Chrome
0056XL0086	Padlocking Body	X-Light Spring	Tuffkote
0056005002	Strike	-1/8" to 1/4" (-3.2 to 6.4 mm)	Polished Chrome
0056005003	Strike	3/4" to 1-1/2" (19.0 to 38.1 mm)	Polished Chrome
0056005005	Strike	1-3/4" to 2-1/2" (44.5 to 63.5 mm)	Polished Chrome
0056005008	Strike	3" to 4" (76.2 to 101.6 mm)	Polished Chrome
0056006002	Strike	-1/8" to 1/4" (-3.2 to 6.4 mm)	Brushed Chrome
0056006003	Strike	3/4" to 1-1/2" (19.0 to 38.1 mm)	Brushed Chrome
0056006005	Strike	1-3/4" to 2-1/2" (44.5 to 63.5 mm)	Brushed Chrome
0056006008	Strike	3" to 4" (76.2 to 101.6 mm)	Brushed Chrome
005600T002	Strike	-1/8" to 1/4" (-3.2 to 6.4 mm)	Tuffkote
005600T003	Strike	3/4" to 1-1/2" (19.0 to 38.1 mm)	Tuffkote
005600T005	Strike	1-3/4" to 2-1/2" (44.5 to 63.5 mm)	Tuffkote
005600T008	Strike	3" to 4" (76.2 to 101.6 mm)	Tuffkote
0056CM0004	Cylinder Kit for 56C models.		

Cylinder locks may be keyed alike or differently; 5 key changes available. Please specify.

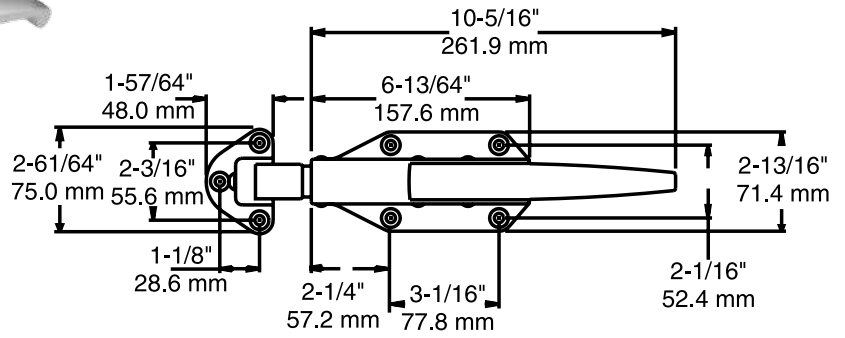

Model No.	Item	Description
0058CH5020	Cylinder Locking Body	Heavy Spring
0058CL5020	Cylinder Locking Body	Light Spring
0058H05021	Body	Heavy Spring
0058L05021	Body	Light Spring
0058005001	Strike	-1/8" to 1/4" (-3.2 to 6.4mm)
0058005002	Strike	3/4" to 1-1/2" (19.0 to 38.1mm)
0058005003	Strike	1-3/4" to 2-1/2" (44.5 to 63.5mm)
0058005310035K	Flat Bottom Plate (Does not accept inside release handle.)	

Cylinder locks may be keyed alike or differently. Please specify.

**FOR ROLLING RADIAL LATCH, ORDER**

**N O . 0059 STRIKE, BELOW.**

Model No.	Item	Description
0059005001	Roller Strike	-1/8" to 1/4" (-3.2 to 6.4 mm)
0059005002	Roller Strike	3/4" to 1-1/2" (19.0 to 38.1 mm)
0059005003	Roller Strike	1-3/4" to 2-1/2" (44.5 to 63.5 mm)

For No. 59 Latch, order strike above with No. 58 body assembly.

**HOW TO SELECT & ORDER INSIDE RELEASE HANDLES**



1. From Table A choose the appropriate inside release handle for each latch.
2. Refer to Table B for minimum door thickness required for each inside release model.
3. Specify exact thickness of your door. We will use this information to convert your requirements into our part numbers.

TABLE A

LATCHES	INSIDE RELEASE HANDLES
45, 46, 50, 51, 4545, 4646, 5050, 5151	480, 481B, 482B, 486B, 487B, 489B
52, 53	481B, 482B, 486B, 487B, 489B
55XXL	486D, 489D
56, 5656	480, 483, 481A, 482A, 486A, 487A, 489A
58, 77, 78, 778	481C, 482C, 486C, 487C, 489C

TABLE B

MINIMUM DOOR THICKNESS	INSIDE RELEASE HANDLES
1-1/2" (38.1 mm)	481C, 482C, 483, 487C
2-1/2" (63.5 mm)	481A, 482A, 487A
2-11/16" (68.3 mm)	486D
2-3/4" (69.9 mm)	489D
3" (76.2 mm)	481B, 482B, 486B, 486C, 487B
3-1/4" (82.6 mm)	489B, 489C
3-1/2" (88.9 mm)	480
3-3/4" (95.3 mm)	486A
4" (101.6 mm)	489A

# 1094 SURECLOSE™ HYDRAULIC DOOR CLOSER

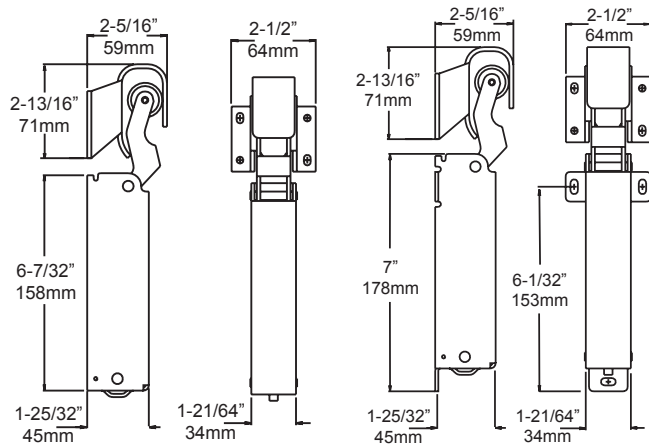

## CONCEALED MOUNTING

## EXPOSED MOUNTING

Model No.	Item	Finish	Wgt/Carton
1094000002	Closer, Exposed Mounting	Brushed Chrome	35 lb. (15.6kg)
1094000003	Closer, Exposed Mounting	Polished Chrome	35 lb. (15.6kg)
1094000012	Closer, Concealed Mounting	Brushed Chrome	35 lb. (15.6kg)
1094000013	Closer, Concealed Mounting	Polished Chrome	35 lb. (15.6kg)
1094S00003	Dual Closer, Exposed Mounting	Polished Chrome	35 lb. (15.6kg)
1094S00012	Dual Closer, Concealed Mounting	Brushed Chrome	35 lb. (15.6kg)
1094S00013	Dual Closer, Concealed Mounting	Polished Chrome	35 lb. (15.6kg)
1094000024	Hook for 1094 Flush (0.0mm)	Brushed Chrome	9.5 lb. (4.3kg)
1094000025	Hook for 1094 Flush (0.0mm)	Polished Chrome	9.5 lb. (4.3kg)
1094000028	Hook for 1094. 1-1/8" (28.6mm) Offset	Brushed Chrome	12.3 lb. (5.5kg)
1094000029	Hook for 1094. 1-1/8" (28.6mm) Offset	Polished Chrome	12.3 lb. (5.5kg)

PACKAGING: Closers and hooks packaged separately; 24 to a carton.

# 1095 SPRING ACTION DOOR CLOSER

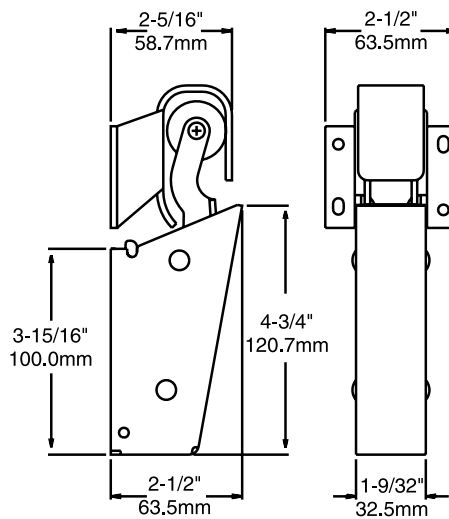

Model No.	Item	Wgt/Carton
1095000013	Closer	30.0 lb (13.6 kg)
1094000025	Hook for 1095, Flush (0.0 mm)	9.5 lb. (4.3 kg)
1094000029	Hook for 1095, 1-1/8" (28.6 mm) Offset	12.3 lb. (5.5 kg)

PACKAGING: Closers and hooks packaged separately; 24 to carton.

## 1236 HEAVY DUTY LEVER LOCKING HANDLE

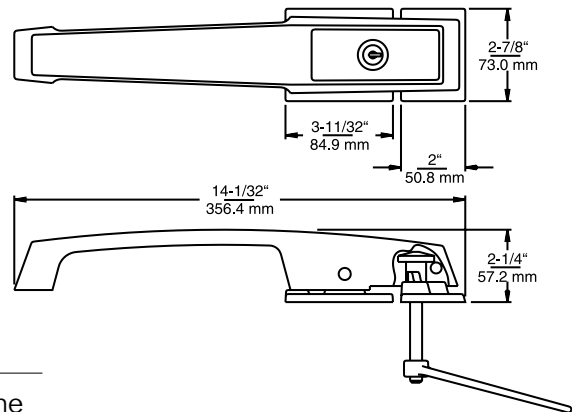

Model No.	Item	Finish
1236C00004	Handle w/ Lever Turn Release	Brushed Chrome
1236C00005	Handle w/ Lever Turn Release	Polished Chrome
1236C00006	Handle w/ Knob Turn Release	Polished Chrome

PACKAGING: 12 per carton.

WEIGHT: Approx. 53 lb. (24.0 kg) per carton.



## 1238 PACESETTER LOCKING HANDLE

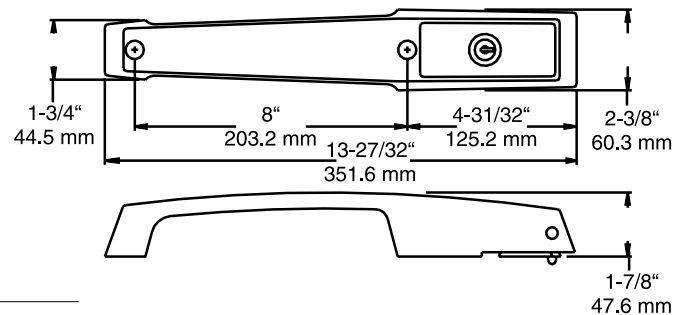

Model No.	Item	Finish
1238CV0005	Cylinder Locking w/Twist-off Knob Release	Smooth Surface, Polished Chrome
1238C00004	Cylinder Locking w/Twist-off Knob Release	Textured Panel, Brushed Chrome
1238C00005	Cylinder Locking w/Twist-off Knob Release	Textured Panel, Polished Chrome
1239CV0005	Cylinder Locking w/Lever Turn Release	Smooth Surface, Polished Chrome
1239C00004D	Cylinder Locking w/Lever Turn Release	Textured Panel, Brushed Chrome
1239C00005	Cylinder Locking w/Lever Turn Release	Textured Panel, Polished Chrome

PACKAGING: 12 per carton.

WEIGHT: Approx. 27 lb. (12.3 kg) per carton.



# 1241 HEAVY DUTY DOUBLE KNUCKLE HINGE

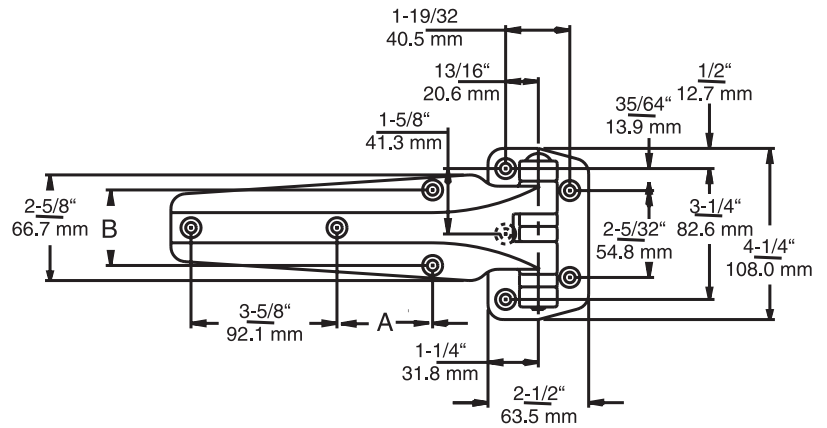

Model No.	Item	Offset	Dim. A	Dim. B	Qty/Carton	Wgt/Carton
1241000004	Hinge	Flush (0.0 mm)	2-3/8" (60.3 mm)	1-13/16" (46.02 mm)	4 pair	20 lb. (8.1 kg)
1241000008	Hinge	1-1/8" (28.6 mm)	2-3/8" (60.3 mm)	1-7/8" (47.6 mm)	3 pair	14 lb. (6.8 kg)
1241H00004	Hinge	Flush (0.0 mm)	1-23/32" (43.6 mm)	1-11/16" (42.9 mm)	4 pair	20 lb. (8.1 kg)
1241S00004	Hinge	Flush (0.0 mm)	1-3/16" (30.2 mm)	1-3/4v (44.4 mm)	4 pair	20 lb. (8.1 kg)

# 1256 PACESETTER HINGE

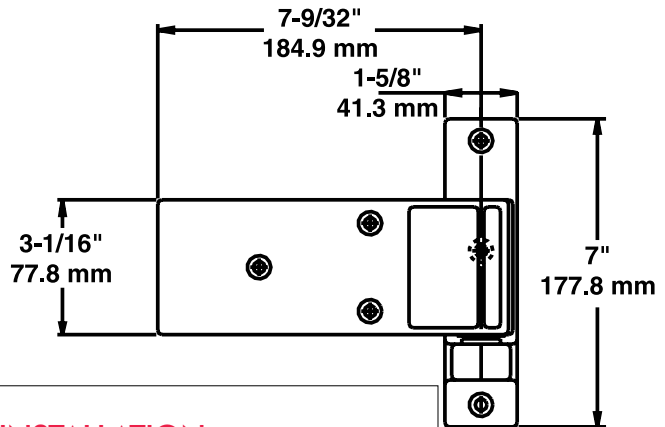

## EASY SPRING CARTRIDGE INSTALLATION

1. Replace existing follower assembly with spring cartridge follower. ylbmesssa
2. Assemble spring cartridge.
3. Remove black plastic cap at top of strap and insert spring assembly into strap so that screw enters hole in cam.
4. Drive screw through rod and secure with acorn nut.

Model No.	Item	Finish	Qty/Carton	Wgt/Cartpn
1256V00004C	Hinge, Smooth Face	Polished Chrome	3 pr.	18 lb. (8.2 kg) per carton
1256000004	Hinge, Textured Panel	Brushed Chrome		
1255000001	Spring Kit for 1255 & 1256	Brushed Chrome	24	Request Weight
1255000003	Spring Kit for 1255 & 1256	Polished Chrome		

# 1245 REVERSIBLE CAM-RISE HINGE

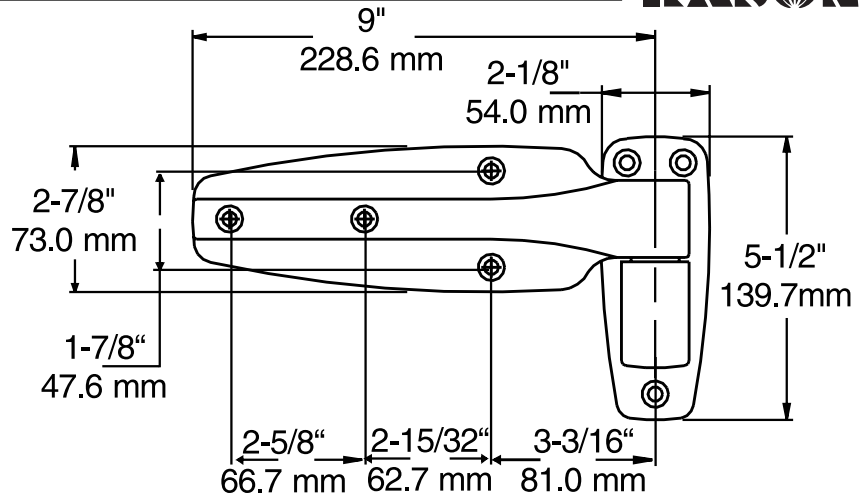

Model No.	Item	Offset	Finish
1245000004	Hinge	Flush (0.0 mm)	Tuffkote
1245000016	Hinge	1-1/8" (28.6 mm)	Tuffkote
1245000020	Hinge	1-1/4" (31.8 mm)	Tuffkote
1245000024	Hinge	1-3/8" (34.9 mm)	Tuffkote
1245000052	Hinge	1-1/2" (38.1 mm)	Tuffkote
1245000056	Hinge	1-5/8" (41.3 mm)	Tuffkote
1245000060	Hinge	1-3/4" (44.5 mm)	Tuffkote
1245000064	Hinge	1-7/8" (47.6 mm)	Tuffkote
1245000028	Hinge	Flush (0.0 mm)	Polished Chrome
1245000040	Hinge	1-1/8" (28.6 mm)	Polished Chrome
1245000044	Hinge	1-1/4" (31.8 mm)	Polished Chrome
1245000048	Hinge	1-3/8" (34.9 mm)	Polished Chrome
1245000068	Hinge	1-1/2" (38.1 mm)	Polished Chrome
1245000072	Hinge	1-5/8" (41.3 mm)	Polished Chrome
1245000076	Hinge	1-3/4" (44.5 mm)	Polished Chrome
1245000080	Hinge	1-7/8" (47.6 mm)	Polished Chrome
1245000082	Hinge	2" (50.8 mm)	Polished Chrome
1245000088	Hinge	Flush (0.0 mm)	Brushed Chrome
1245000112	Hinge	1-1/8" (28.6 mm)	Brushed Chrome
1245000116	Hinge	1-1/4" (31.8 mm)	Brushed Chrome
1245000120	Hinge	1-3/8" (34.9 mm)	Brushed Chrome
1245000124	Hinge	1-1/2" (38.1 mm)	Brushed Chrome
1245000128	Hinge	1-5/8" (41.3 mm)	Brushed Chrome
1245000132	Hinge	1-3/4" (44.5 mm)	Brushed Chrome
1245000136	Hinge	1-7/8" (47.6 mm)	Brushed Chrome
1245000138	Hinge	2" (50.8 mm)	Brushed Chrome

PACKAGING: 3 pair per carton.

WEIGHT: Approx. 18 lb. (8.2 kg) per carton.



## REVERSE HINGES IN MINUTES

1. Lift strap from flange and remove pin assembly.



2. Pop out cap. Turn strap 180°, reinsert pin assembly in strap.



3. Reposition strap into flange and replace cap.

# 1248 SPRING ASSISTED HINGE



Model No.	Item	Offset	Finish
1248000004	Hinge	Flush (0.0 mm)	Polished Chrome
1248000016	Hinge	1-1/8" (28.6 mm)	Polished Chrome
1248000020	Hinge	1-1/4" (31.8 mm)	Polished Chrome
1248000024	Hinge	1-3/8" (34.9 mm)	Polished Chrome
1248000022	Hinge	1-1/2" (38.1 mm)	Polished Chrome
1248000025	Hinge	1-5/8" (41.3 mm)	Polished Chrome
1248000026	Hinge	1-3/4" (44.5 mm)	Polished Chrome
1248000027	Hinge	1-7/8" (47.6 mm)	Polished Chrome
1248000030	Hinge	2" (50.8 mm)	Polished Chrome
1248000028	Hinge	Flush (0.0 mm)	Brushed Chrome
1248000040	Hinge	1-1/8" (28.6 mm)	Brushed Chrome
1248000044	Hinge	1-1/4" (31.8 mm)	Brushed Chrome
1248000048	Hinge	1-3/8" (34.9 mm)	Brushed Chrome
1248000049	Hinge	1-5/8" (41.3 mm)	Brushed Chrome
1248000050	Hinge	1-3/4" (44.5 mm)	Brushed Chrome
1248000051	Hinge	1-7/8" (47.6 mm)	Brushed Chrome
1248000078	Hinge	2" (50.8 mm)	Brushed Chrome

PACKAGING: 3 pair per carton.

WEIGHT: Approx. 19.5 lb. (8.85 kg) per carton.

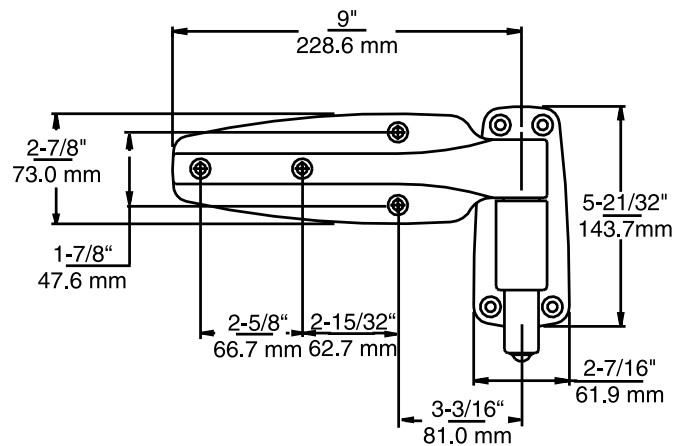

# 5656 TWO-POINT LOCKING LATCH

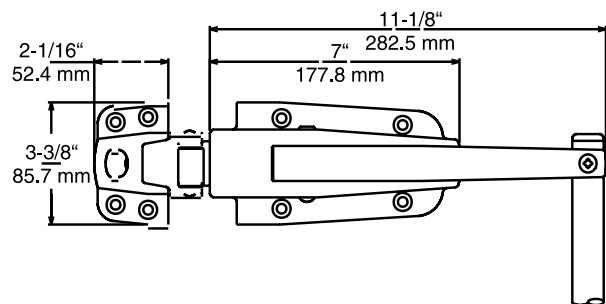

Model No.	Item	Description	Finish
5656CL0004	Cylinder Locking Two Point Latch	-1/8" to 1/4" (-3.2 to 6.4 mm)	Polished Chrome
5656L00004	Padlocking Two Point Latch	-1/8" to 1/4" (-3.2 to 6.4 mm)	Polished Chrome



	A	B*	C
<b>1830</b>	5-3/32" (129.4 mm)	4" (101.6 mm)	3-1/2" (88.9 mm)
<b>1834</b>	5-3/32" (129.4 mm)	4" (101.6 mm)	3-1/2" (88.9 mm)
<b>1832</b>	6-1/4" (165.1 mm)	4" (101.6 mm)	4-5/8" (117.5 mm)
<b>1836</b>	6-1/4" (165.1 mm)	4" (101.6 mm)	4-5/8" (117.5 mm)

\*Other lengths available. Please specify.

### STANDARD VENTILATOR PORTS

Model No.	Item
1830000004	Heated Vent, 23W, .2 amp @ 120 VAC
1830000008	Heated Vent, 23W, .1 amp @ 240 VAC
1830000016	Heated Vent, 20W, .8 amp @ 24 VAC
1834000004	Non-heated Vent

### HIGH-FLOW VENTILATOR PORTS

Model No.	Item
1832000004	Heated Vent, 23W, .2 amp @ 120 VAC
1832000008	Heated Vent, 23W, .1 amp @ 240 VAC
1832000016	Heated Vent, 20W, .8 amp @ 24 VAC
1832SA0004	Heated Vent w/Sq. Aluminum Louver, 120 VAC
1832SS0004	Heated Vent w/Sq. Stainless Steel Louver, 120 VAC
1832SA0001	Sq. Aluminum Louver for 1832 Vent
1832SS0001	Sq. Stainless Steel Louver for 1832 Vent
1836000004	Non-heated Vent
1836SA0001	Non-heated w/Sq. Aluminum Louver
1836SS0001	Non-heated w/Sq. Stainless Steel Louver

## NOTE

All 1830 Series ventilators are for a 4" (101.6mm) thick wall. When other length is required, specify exact wall thickness. Kason will convert your individual requirement into our part number.

## Kason 1825, 1830 & 1832 VENTILATOR QUANTITY SELECTOR

Volume of Cooler or freezer		Quantity of Ventilators Required (see notes)					
		Cooler <sup>(2)</sup> +10°F (-12.2°C) to +40°F (4.4°C)			Freezer <sup>(2)</sup> +20°F (-28.9°C) to +10°F (12.2°C) <sup>(6)</sup>		
		1825	1830	1832 <sup>(5)</sup>	1825	1830	1832 <sup>(5)</sup>
ft <sup>3</sup>	(m <sup>3</sup> )						
2,000	(57)	1	1	1	1	1	1
3,000	(85)	1	1	1	1	2	1
4,000	(113)	1	1	1	2	3	1
6,000	(170)	1	2	1	3	4	2
8,000	(226)	2	2	1	3 <sup>(5)</sup>		2
12,000	(340)	2	3	1	4 <sup>(5)</sup>	see note 4	3
16,000	(453)	3	4	2	4 <sup>(5)</sup>		4
20,000	(566)	use 1832		2	see note 5		
24,000	(679)			2			

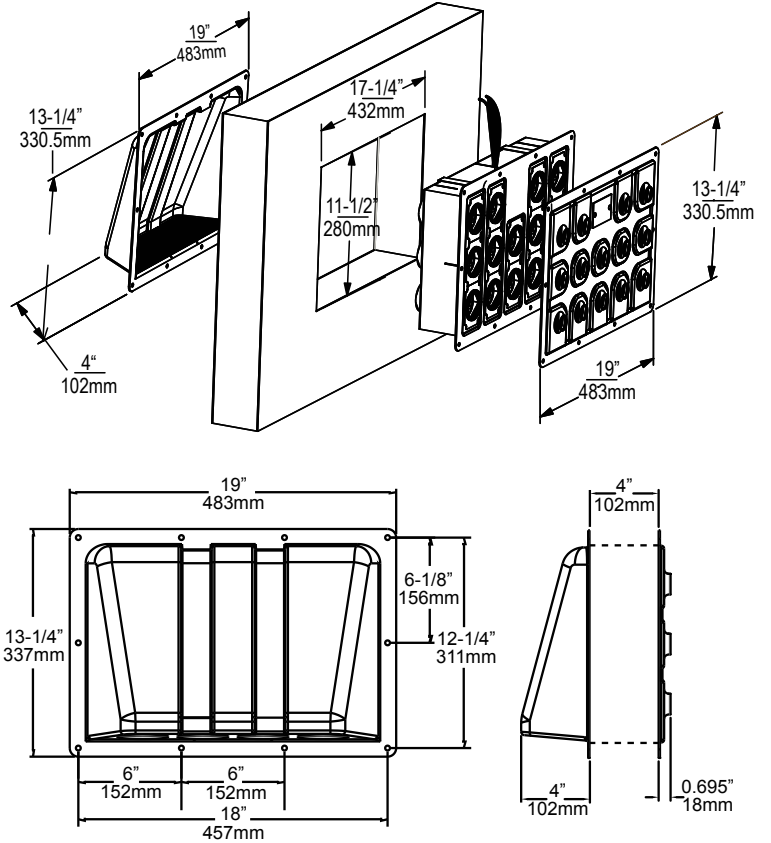

Model No.	Description	Qty/ Carton	Weight/Carton
1845000014	Freezer Ventilator, 120 VAC	1	10 lb. (4.5kg)
1845000014220	Freezer Ventilator, 240 VAC	1	10 lb. (4.5kg)

Refer to Flow Chart & Quantity Selector to determine quantity needed.

Replacement parts available from Kason.

### 1845 Ventilator Flow Rates

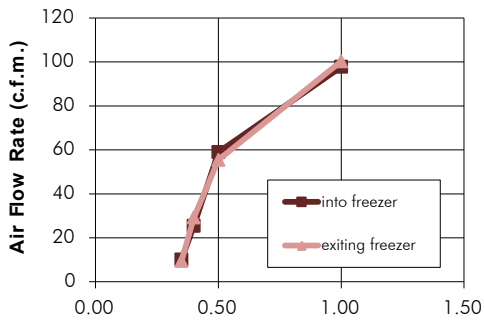

Pressure Differential (Inches of Water)

1845 VE NTILATOR QU AN TITY SELECTOR		
Volume of Cooler or Freezer Ft <sup>3</sup>	(meter <sup>3</sup> )	Quantity
25,000	(708)	1
50,000	(1,415)	2
75,000	(2,123)	3
100,000	(2,830)	4
200,000	(5,660)	8

Notes

(A) Minimum temperature of use is -20F.

(B) For room sizes between two listings, use the higher quantity.

(C) The table above should be used as a general guideline only. Kason does not guarantee these numbers, as many factors beyond those assumed can affect the amount of ventilation required in a refrigerated space. Some of these factors include, but are not limited to: the number of doors in the enclosure, air-tightness of the enclosure, refrigeration load (how quickly the temperature drops), strength of panel construction, etc.

Kason Industries, Inc. 1845 VENTILATOR QUANTITY SELECTOR			
Volume of Cooler or Freezer, Ft <sup>3</sup> (meter <sup>3</sup> )	Quantity	Notes	
25,000 (708)	1	(A) Minimum temperature of use is -20F.	
50,000 (1,415)	2	(B) For room sizes between two listings, use the higher quantity.	
75,000 (2,123)	3	(C) The table above should be used as a general guideline only. Kason does not guarantee these numbers, as many factors beyond those assumed can affect the amount of ventilation required in a refrigerated space. Some of these factors include, but are not limited to: the number of doors in the enclosure, air-tightness of the enclosure, refrigeration load (how quickly the temperature drops), strength of panel construction, etc.	
100,000 (2,830)	4		
200,000 (5,660)	8		

## 1168RP FOAMED-IN-PLACE STRIKE ( CAM LOCKS)

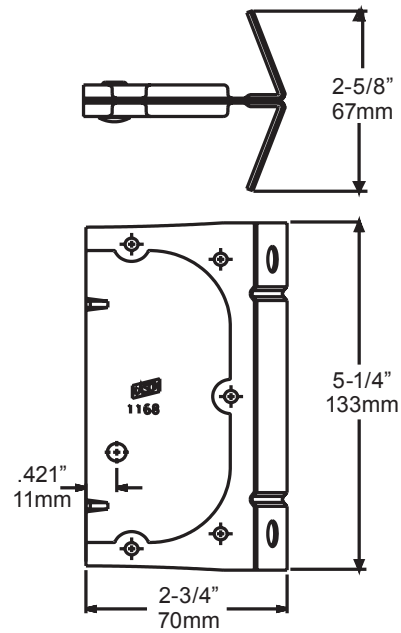

Model No.	Item	Qty./Ctn.	Wgt./Carton
1168RP0008S	Strike	300	103 lb. (46 kg)
1168RP0008SB	Strike	1500	561 lb. (255 kg)
1168RP0008SM	Strike	450*	170 lb. (77 kg)

## 1168RBP FOAMED-IN-PLACE LOCKING POINT ( CAM LOCKS)

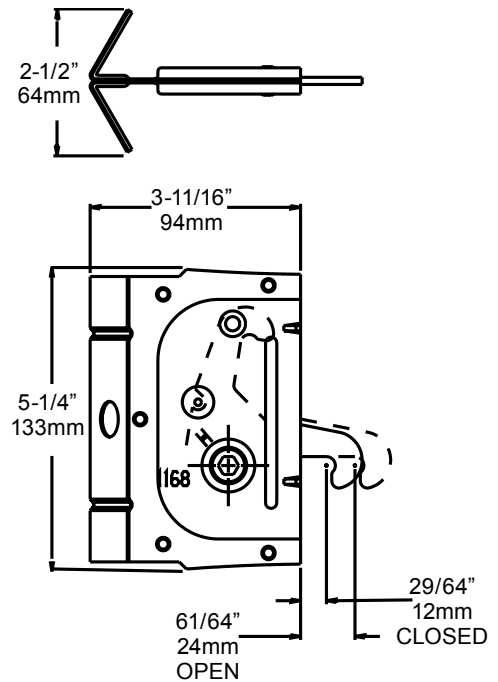

Model No.	Item	Qty./Ctn.	Wgt./Carton
1168RBP004S	Locking Point	250	144 lb. (65 kg)
1168RBP004SB	Locking Point	1000	622 lb. (282 kg)
1168RBP004SM	Locking Point	350*	202 lb. (92 kg)

# 1802, 1803 AND 1804 VAPOR-PROOF INCANDESCENT LIGHT FIXTURES

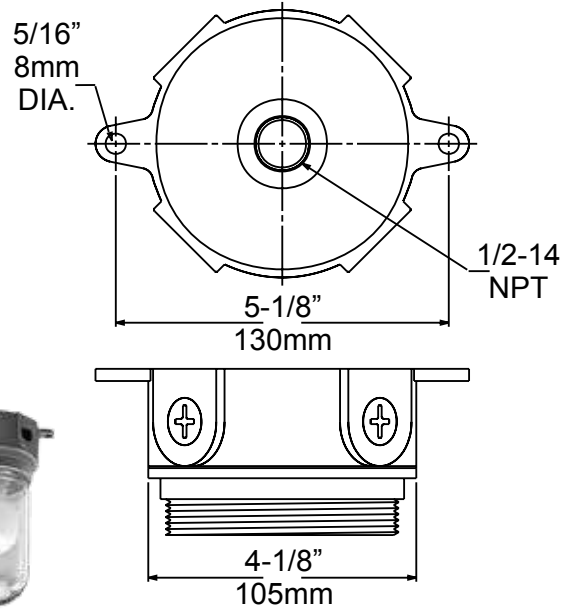

Model No.	Item	Lamp Accepted (not included)	Qty/ Carton	Wgt/Carton
1802LG0000	Fixture w/Glass Globe	100W Max.	25	69 lb. (31kg)
1803LG0000	Fixture w/Lexan Globe	75W Max.	25	49 lb. (22kg)
1804LG0034	Fixture w/Plastic-coated Glass Globe, tapped for 3/4" pipe	100W Max.	25	69 lb. (31kg)
1804LG0000	Fixture w/Plastic-coated Glass Globe	100W Max.	25	69 lb. (31kg)
1802000001	Glass Globe for 1802	-	25	24 lb. (11kg)
1802000002	Wire Guard for 1802	-	50	22 lb. (10kg)
1802000003	Junction Box for 1802	100W Max.	25	25 lb. (11kg)
1803000001	Lexan Globe for 1803	-	25	6 lb. (3kg)
1804000001	Plastic-coated Glass Globe for 1804	-	25	24 lb. (11skg)

LIGHT DISTRIBUTION FOR 1803					
Height in Feet	Average Ft. Candles for Single Fixture Over Indicated Area				
	4' x 4'	8' x 8'	12' x 12'	16' x 16'	20' x 20'
4	17.6	31.1	9.7	7.4	5.8
5	11.9	9.5	7.4	5.9	4.7
6	8.5	7.2	5.9	4.8	3.9
7	6.4	5.6	4.7	3.9	3.3
8	5.0	4.5	3.9	3.3	2.8
9	4.0	3.6	3.2	2.8	2.4
10	3.2	3.0	2.7	2.4	2.1
11	2.7	2.5	2.3	2.1	1.9
12	2.3	2.2	2.0	1.8	1.6

LIGHT DISTRIBUTION FOR 1802 & 1804					
Height in Feet	Average Ft. Candles for Single Fixture Over Indicated Area				
	4' x 4'	8' x 8'	12' x 12'	16' x 16'	20' x 20'
4	21.3	15.8	11.7	8.9	7.0
5	14.4	11.5	9.0	7.1	5.7
6	10.3	8.7	7.1	5.8	4.8
7	7.8	6.8	5.7	4.8	4.0
8	6.0	5.4	4.7	4.0	3.4
9	4.8	4.4	3.9	3.4	3.0
10	3.9	3.6	3.3	2.9	2.6
11	3.3	3.1	2.8	2.5	2.2
12	2.7	2.6	2.4	2.2	2.0

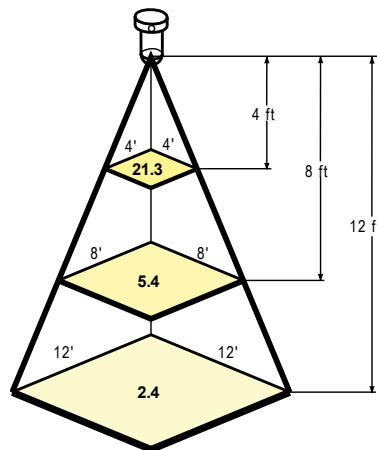
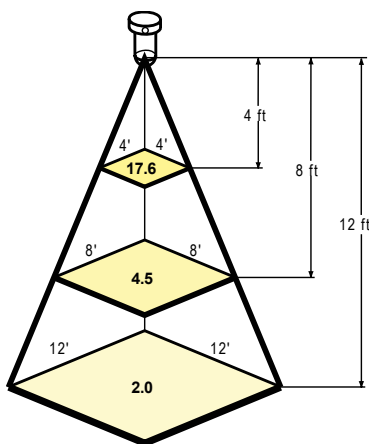

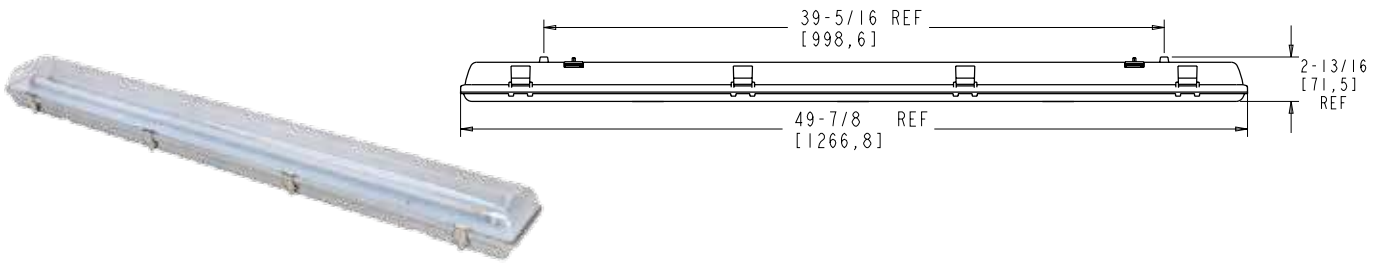

**HIGH OUTPUT THAT HELPS YOU SAVE** High output LED technology with best-in-class efficiency at 96 lumens per watt. Designed for high ceilings and larger work rooms with greater foot candle requirements; you get the same output from fewer fixtures.

**SUSTAINABLE** LED technology assures sustainable energy savings over the life of the fixture. Four-foot, vaporproof fixture is supplied complete with low energy LEDs.

**FAST RETURN** Payback in as little as six (6) months. Reduced lighting wattage and heat generation lower utility cost. LED fixtures are rated 50,000+ hr/life. Find your specific savings using the Kason Payback Calculator.

**WET & COLD APPLICATIONS** Specifically designed for wet and low temperature environments. Operating temperature range from -40° F to 104° F (-40° C to 40° C). Luminaire meets IP-65 for wet and cold applications and is LM-79 tested.

**INSTANT ON** Reach full light level immediately even in lowest temperatures. No more waiting for freezer lights to warm up.

**FAST RETROFIT** Easily replaces less energy-efficient lighting.

Model No.	Description	Weight	Compliance
1810LX4000	4 Ft. LED Light Fixture	6.3 lbs./fixture	UL, NSF
1810LX40CE	4 Ft. LED Light Fixture	6.3 lbs./fixture	CE, NSF

\*Rebates may apply through local utility companies.

**ELECTRICAL SPECIFICATIONS**

- Unbreakable polycarbonate enclosure
- Pre-installed Surface Mount LED Strips mean no more tubes
- 39W total, 0.33 amps, 100-277VAC (universal input) 50/60 Hz.
- System Luminance: 3770 lumens
- 96 lumens/watt - exceeds Federal Energy Act requirement
- Luminaire Rating IP-65 for wet and cold environments
- No ultraviolet emission: Does not attract insects
- Constant Current LED
- 4500K color temperatures
- Rated 50,000+ hrs. of life
- 5 year limited warranty
- RoHS compliant and mercury free
- Fixture: UL Listed for US & Canada
- Class 2 Power Supply is a ANSI/UL-CSA recognized component and bears the RoHS and CE marks
- LM-79 & LM-80 Tested

LIGHT DISTRIBUTION FOR 1810LX				
Height in Feet	Average FC for Single Fixture Over Indicated Area			
	8' x 8'	12' x 12'	16' x 16'	20' x 20'
5	30.9	17	10.7	7.4
8	22.5	13.2	8.7	6.2
9	-	12.2	8.2	5.9
12	-	10.0	6.9	5.1
13	-	-	6.5	4.8
16	-	-	5.6	4.2
17	-	-	-	4.0
20	-	-	-	3.6

**1908 Weather Proof Rocker Switch & Cover Plate**



Ref.	Model No.	Item
A	EEAI000277	Switch, Single Pole
	EEAI000277C	Switch, Single Pole, CSA Listed
	EEAI000294	Switch, 3-way
	EEAI000294C	Switch, 3-way, CSA Listed
B	EEA00000S8	Cover Plate for Switches (A)
C	EEABL00827	Receptacle, 15 Amps.
	EEABL00877	Receptacle, 20 Amps.
D	ELE0000100	Blank Cover Plate
E	ELE0000101	Cover Plate for Single Switch
F	ELE0000102	GFCI Receptacle & Cover Plate
G	1908000602	Waterproof Rocker Cover
	1908000603	Waterproof Rocker Switch, Single or 3-way.
	1908000604	Waterproof Rocker Switch, 4-way.

0218 ADJUSTABLE SPRING HINGE

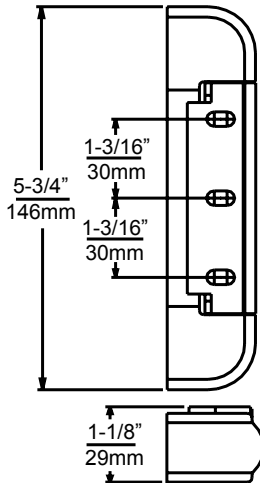

TO INSTALL  
SPRING  
CARTRIDGE

Depress bushing and slip the spring-loaded cartridge in place. Perform this simple operation in the field in minutes.

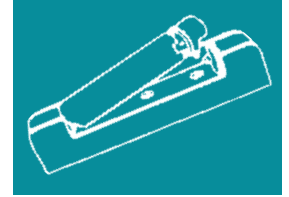

Model No.	Item	Offset
0218000004	Hinge	7/8" (22.2mm)
0218000008	Hinge	1-1/8" (28.6mm)
0218000012	Hinge	1-3/8" (34.9mm)
0218000028	Spring Cartridge Kit	

PACKAGING: Hinges, 12 pair per carton.  
Spring Kit, 48 per carton.

WEIGHT: Hinges, 33 lb. (15.0 kg) per carton.

0220 SPRING HINGE

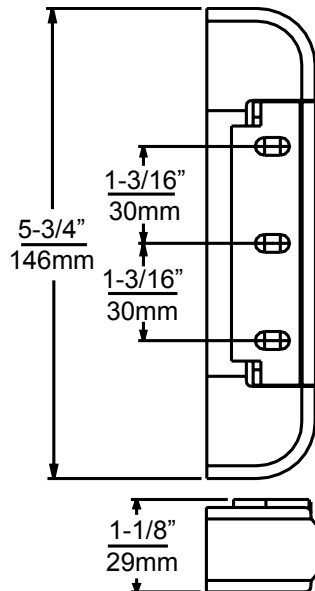

220 SPRING CARTRIDGE  
KIT INSTALLATION

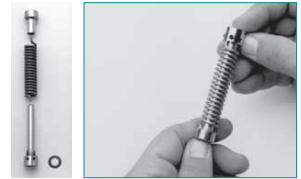

1. Assemble spring cartridge as shown.



2. Place thrust washer and bushing over hexagon pin on mounted hinge. Insert adjustment pin into adjustment bushing assembly. Grasping adjustment pin, compress spring and place adjustment bushing assembly over round pin.



3. Adjust tension; then insert stop pin in hole of adjustment bushing assembly.

Model No.	Item	Offset
0220000008	Hinge	1-1/8" (28.6 mm)
0220000012	Hinge	1-3/8" (34.9 mm)
0220S00012	120° Stop Hinge	1-3/8" (34.9 mm)
0220S00013	90° Stop Hinge	1-3/8" (34.9 mm)
0220000027	Spring Cartridge Kit	

PACKAGING: 12 pair per carton.

WEIGHT: Approx. 18 lb. (8.2 kg) per carton.

# 1216-31 HI-TEMP BRASS OVEN HINGE

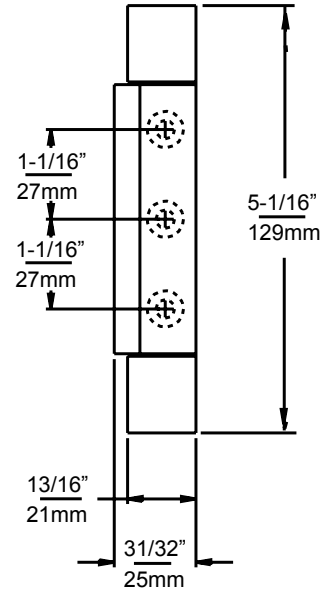

Model No.	Item	Description
1216000031	Hi Temp Hinge	Solid Brass
1216000027	Spring Cartridge Kit	

PACKAGING: 20 pair per carton.

WEIGHT: Approx. 31 lb. (14 kg) per carton.

### OPTIONAL 1216-27 SPRING CARTRIDGE KIT

Easily convert the 1216 Hi Temp to a spring hinge with this kit.



# 0170 SERIES MAGNETIC LATCHES

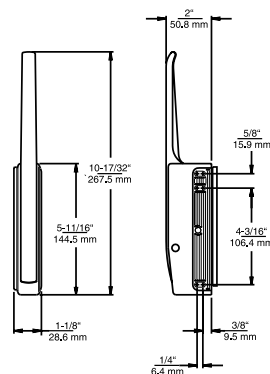

170 STRAIGHT DIE-CAST OR COMPOSITE HANDLE

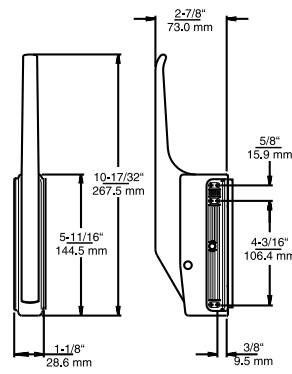

170 COMPOSITE OFFSET HANDLE

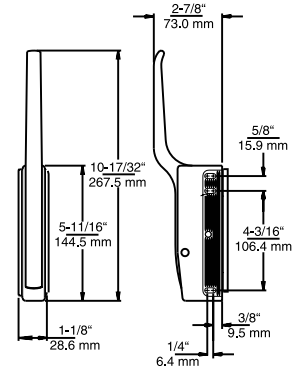

170 DIE-CAST OFFSET HANDLE

Model No.	Handle	Magnet	Quantity/ Carton	Weight/ Carton
0170000008	Offset Composite, Black	Standard	12	27 lb. (12.3kg)
0170000018	Offset Composite, Black	Ceramic	12	27 lb. (12.3kg)
0170S00004	Straight Die-cast, Pol.Chrome	Standard	12	27 lb. (12.3kg)
0170S00014	Straight Die-cast, Pol.Chrome	Ceramic	12	27 lb. (12.3kg)
0170S00008	Straight Composite, Black	Standard	12	27 lb. (12.3kg)
0170S00018	Straight Composite, Black	Ceramic	12	27 lb. (12.3kg)
0170B00024	Offset, Die-cast, Pol.Chrome	Standard	12	34 lb. (15.3kg)
0170B00034	Offset, Die-cast, Pol.Chrome	Ceramic	12	34 lb. (15.3kg)

# 1522 TOP PIVOT HINGE

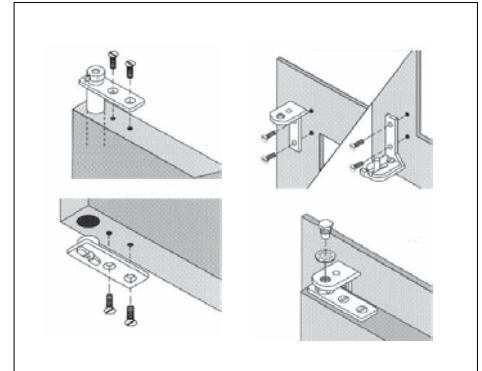
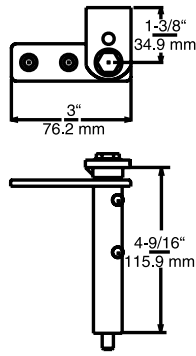

Model No.	Item	Quantity/Carton	Weight/Carton
1522L00004	Top Left Hand Hinge	50	30 lb. (13.6kg)
1522R00008	Top Right Hand Hinge	50	30 lb. (13.6kg)
1521L00004	Bottom Left Hand Hinge	50	21 lb. (9.5kg)
1521R00008	Bottom Right Hand Hinge	50	21 lb. (9.5kg)

# 1556 POWER CARTRIDGE ASSEMBLIES

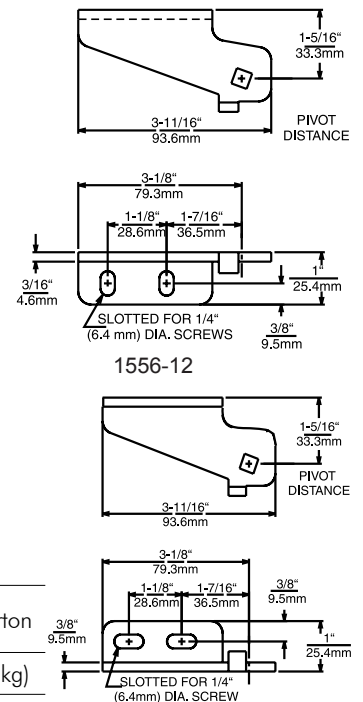
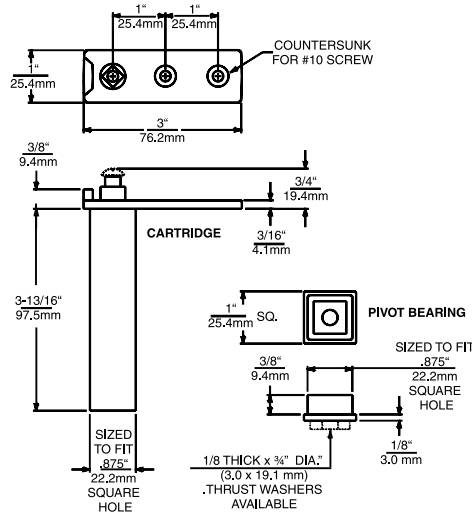

Model No.	Item	Quantity/Carton	Weight./Carton
1556000004	Spring Cartridge Assembly, Standard Clearance, 120° stop.	48	24 lb. (10.9kg)
1556000008	Spring Cartridge Assembly, Minimal Clearance, no stop.	48	24 lb. (10.9kg)
1556000011	Top Left Hand Cartridge Bracket	24	8 lb. (3.6kg)
1556000012	Top Right Hand Cartridge Bracket	24	8 lb. (3.6kg)
1556000013	Bottom Left Hand Cartridge Bracket	24	8 lb. (3.6kg)
1556000014	Bottom Right Hand Cartridge Bracket	24	8 lb. (3.6kg)
1556000021	Top Left Hand Pivot Bracket	24	8 lb. (3.6kg)
1556000022	Top Right Hand Pivot Bracket	24	8 lb. (3.6kg)
1556000023	Bottom Left Hand Pivot Bracket	24	8 lb. (3.6kg)
1556000024	Bottom Right Hand Pivot Bracket	24	8 lb. (3.6kg)
1556000035	Double Left Hand Pivot Bracket	24	8 lb. (3.6kg)
1556000036	Double Right Hand Pivot Bracket	24	8 lb. (3.6kg)
1556000257	Thrust Washer, 1/8" (3.2mm) for 1556 Hinge	100	1 lb. (0.45kg)

**1651 FOOT INSERTS FOR ROUND TUBING AND PIPE**

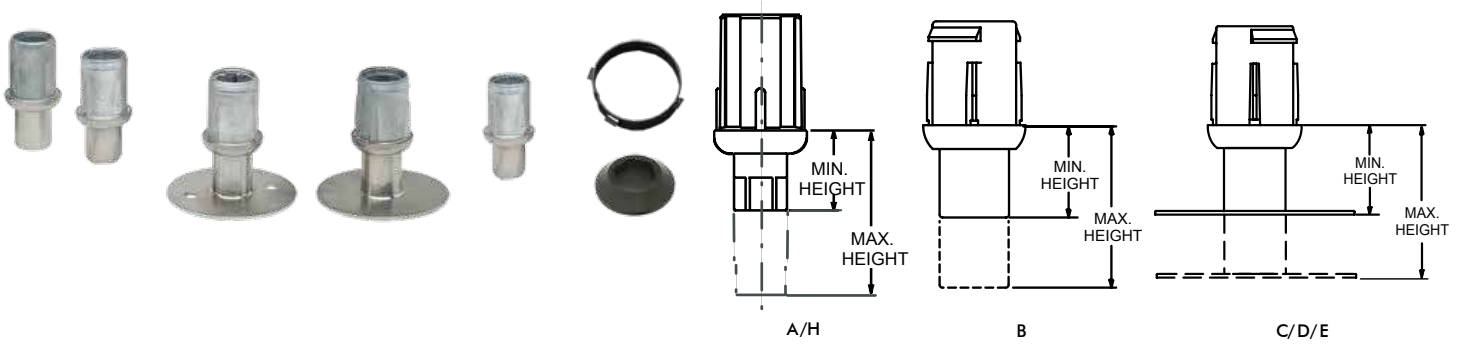

1651 ADJUSTABLE FOOT INSERTS							
Application	Ref.	Model No.	Body	Foot	Min.Height	Max. Height	Static Load Rating lbs.(kg)/ft.
1-5/8" (41mm) O.D. Round Tubing	A	1651000257*	SS Clad Zamak	Hex**	1-1/2" (38mm)	2-5/8" (66mm)	2,000 (907)
	B	1651000256*	Die-cast Zamak	SS Clad Round	1-1/2" (38mm)	2-5/8" (66mm)	2,000 (907)
	C	1651000357*	SS Clad Zamak	3-1/2" SS Flange, 2 Mounting Holes	1-1/2" (38mm)	2-5/8" (66mm)	2,000 (907)
	D	1651000358*	SS Clad Zamak	3-1/2" SS Flange, No Mounting Holes	1-1/2" (38mm)	2-5/8" (66mm)	2,000 (907)
	E	1651000359	SS Clad Zamak	2-5/8" SS Flange, 2 Mounting Holes	1-1/2" (38mm)	2-5/8" (66mm)	2,000 (907)
	Nor Shown	1650001000	*Locking Ring for C thru H				
	1651000001	**Large Black Plastic Glide for E					

**INSERT FOR 1-1/4 IN. (30MM) I.P.S. PIPE AND 1-1/2 IN. (38MM) O.D. 16 GA. TUBING**

ADJUSTABLE FOOT INSERT FOR PIPE & TUBING							
Application	Ref.	Model No.	Body	Foot	Min.Height	Max. Height	Static Load Rating lbs.(kg)/ft.
1-1/4" (30mm) Pipe & 1-1/2" (38mm) O.D.Tubing	H	1651000157	Natural Zamak	SS Clad Hex	1-1/2" (38mm)	2-5/8" (66mm)	2,000 (907)

**1652 SERIES FOOT INSERTS FOR SQUARE TUBING**

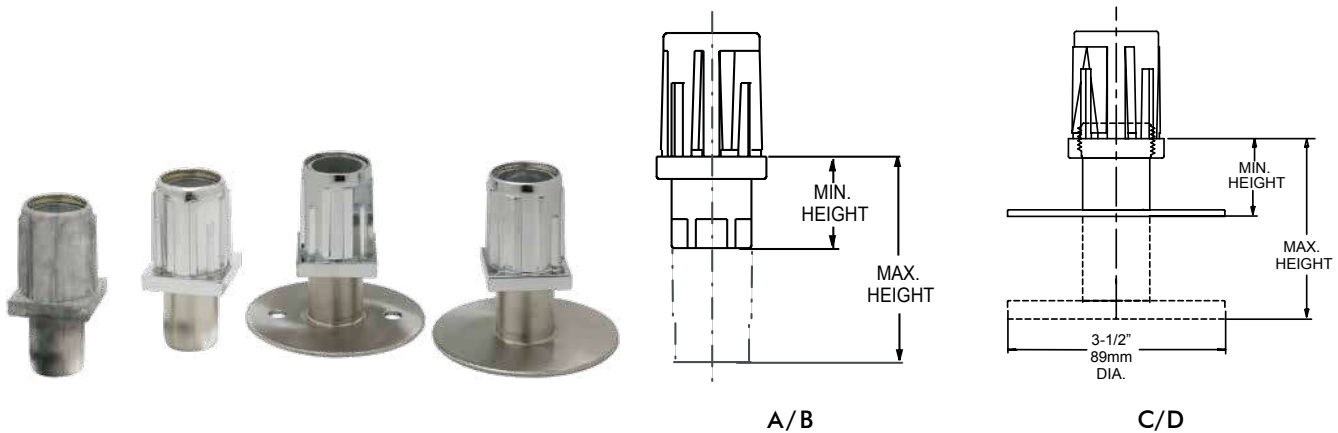

1652 FOOT INSERTS						
Application	Ref.	Model No.	Body	Foot	Min. Height	Max. Height
1-1/2" (38mm) Square Tubing, 16 GA. or 18 GA.	A	1652000257	Die-cast Zamak	Die-cast Zamak Hex	1-5/16" (33mm)	2-7/16" (62mm)
	B	1652000258	Nickel Plated	SS Clad Hex	1-1/2" (38mm)	2-5/8" (66mm)
	C	1652000357	Chrome Plated Zamak	SS Flange, 2 Holes	1-1/2" (38mm)	2-5/8" (66mm)
	D	1652000358	Chrome Plated Zamak	SS Flange, No Holes	1-1/2" (38mm)	2-5/8" (66mm)
STATIC LOAD RATING 2000 LB. (907kg) PER FOOT.						

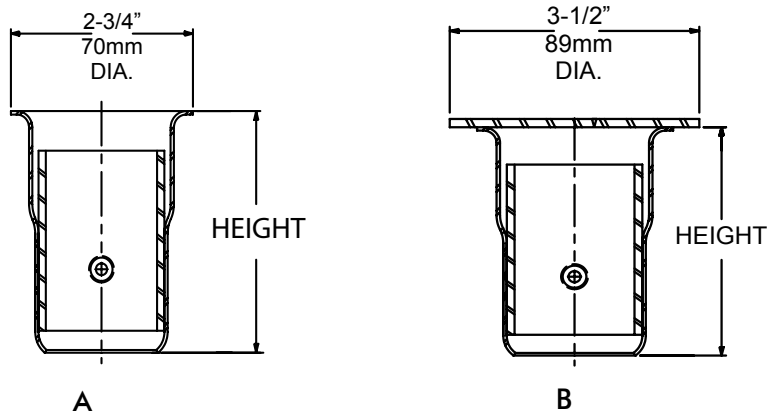

1654 STAINLESS STEEL LEG SOCKETS				
Application	Ref.	Model No.	Description	Height
1-5/8" (40mm) O.D. Tubing or 1-1/4" (30mm) I.P.S. Pipe	A	1654000260	Bell Top, 1 Set Screw	3-7/16" (87mm)
	B	1654000280	Bell Top, Welded Plate, 1 Set Screw	3-9/16" (91mm)
	Not Shown	1655000003	NSF Plastic Plug for 3/8-24 Hex Screw	

SET SCREWS PROVIDED. TO ORDER ADDITIONAL 3/8-24 SET SCREWS, SPECIFY PART NO. 1655000001.

# 1655 LEG SOCKETS FOR ROUND TUBING & SERIES TUBULAR SHELF SUPPORTS

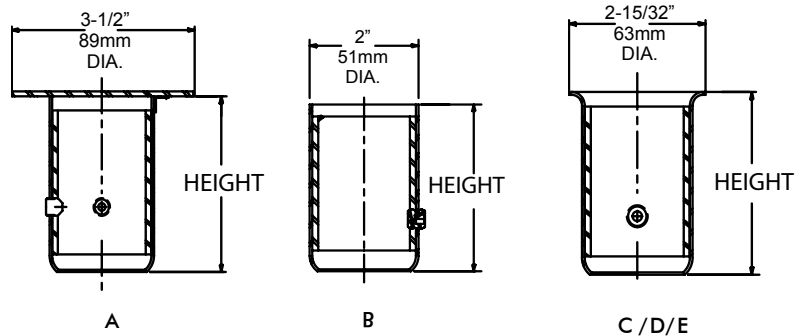

1655 STAINLESS STEEL LEG SOCKETS				
Application	Ref.	Model No.	Description	Height
1-5/8" (40mm) O.D. Tubing or 1-1/4" (30mm) I.P.S. Pipe	A	1655000282	Straight top, Welded Plate, 2 Set Screws	3-1/4" (83mm)
	B	1655000261	Straight Top, 1 Set Screw	3-3/16" (81mm)
	C	1655000260	Flanged Top, 1 Set Screw	3-1/8" (79mm)
	D	1655000263	Flanged Top, 2 Set Screws	3-1/8" (79mm)
	E	1655000264	Flanged Top, 1 Set Screw	1-3/4" (45mm)
Not Shown		1655000003	NSF Plastic Plug for 3/8-24 Hex Screw	

SET SCREWS PROVIDED. TO ORDER ADDITIONAL 3/8-24 SET SCREWS, SPECIFY PART NO. 1655000001.

1655 SERIES TUBULAR SHELF SUPPORTS		
Model No.	Description	Height
1655000271	S/S w/Liner	3-3/16" (80mm)
1655000272	S/S w/Liner	5-1/4" (133.4mm)

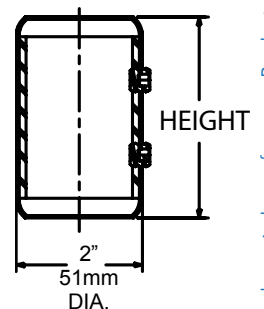

# 1751 SEISMIC RESTRAINT AND SECURITY LEGS

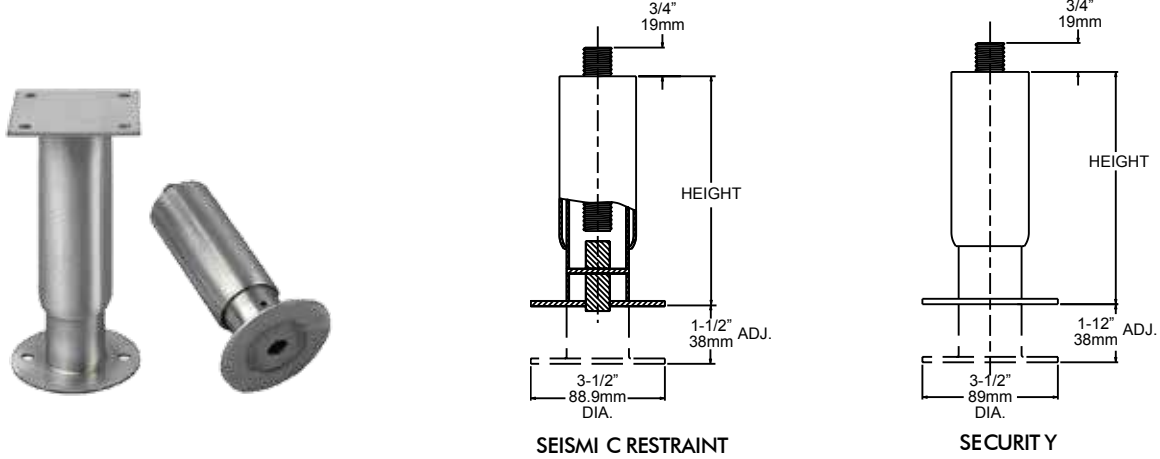

SEISMI C RESTRAINT

SECURITY

SEISMI C AND SECURITY LEG ASSEMBLY SELECTOR				
Leg Type	Tubing	Height	Leg Top	
			Stud	Welded Mounting Plate
Seismic Restraint	1751 Series 2" (50mm) O. D., 16 GA. (1.5mm) Stainless Steel	Specify in 1/8" (3mm) increments from 4" (102mm) to 36" (914mm).	Thru Stud 1/2 -13 5/8 -11 3/4 -10	3-1/2" sq. (89mm), Round Holes
Security	1752 Series 1-5/8" (40mm) O. D., 16 GA (1.5mm) Stainless Steel	Some restrictions apply.	Flush Stud 1/2 -13 5/8 -11 3/4 -10	2-1/2" x 3-5/8" (64 x 92mm), Slotted Holes 4-5/16" x 3-1/4" (110 x 83mm), Round Holes

# 1755 LEG SOCKET FOR ROUND TUBING



U.S. Pat. No. 4,793,579

1755 STAINLESS STEEL LEG SOCKETS			
Application	Model No.	Description	Height
1-5/8" (40mm) O.D. Tubing or 1-1/4" (30mm) I.P.S. Pipe	1755000260	Flanged Top, Unlined, 1 Set Screw	3-1/8" (79mm)
Not Shown	1655000003	NSF Plastic Plug for 3/8-24 Hex Screw	

SET SCREWS PROVIDED. TO ORDER ADDITIONAL 3/8-24 SET SCREWS, SPECIFY PART NO. 1655000001.

# 1760 HEAVY DUTY EQUIPMENT LEGS



1760 SERIES LEG ASSEMBLY OPTIONS			
Tubing	Heights/Adjustments	Top Styles	Foot Style
Stainless Steel Clad 1-5/8" (40mm) O. D. 2" (50mm) O. D.	4" (102mm) / 1-3/4" (45mm) 5" (127mm) / 2" (50mm) 6" (152mm) / 2" (50mm)	Flush Stud 3/8-16 1/2-13 5/8-11 3/4-10	Round Plastic Glide
		Through Stud 3/8-16 1/2-13 5/8-11 3/4-10	

REMOVABLE MOUNTING PLATES SOLD AND PACKED SEPARATELY.

STATIC LOAD RATING 2000 LB. (907kg) PER FOOT.

# SLIDING & HINGED DOORS



- **Wide Range Insulated Doors for the Food Industry.**
- **Hardware and Accessories for Chiller & Freezer Door Applications.**
- **Parts & Components for Manual Sliding & Hinged Doors.**
- **Electricity Operated Sliding System.**



# Door Accessories

## Sliding & Hinged Doors Accessories

### Door & Frame Heaters

### Pressure Relief Valves

### Gaskets



06H100250

06H100229

06H100101

06H100503

06H100208



06H100150

06H100151

06H2001171

06H100746

06EL00012

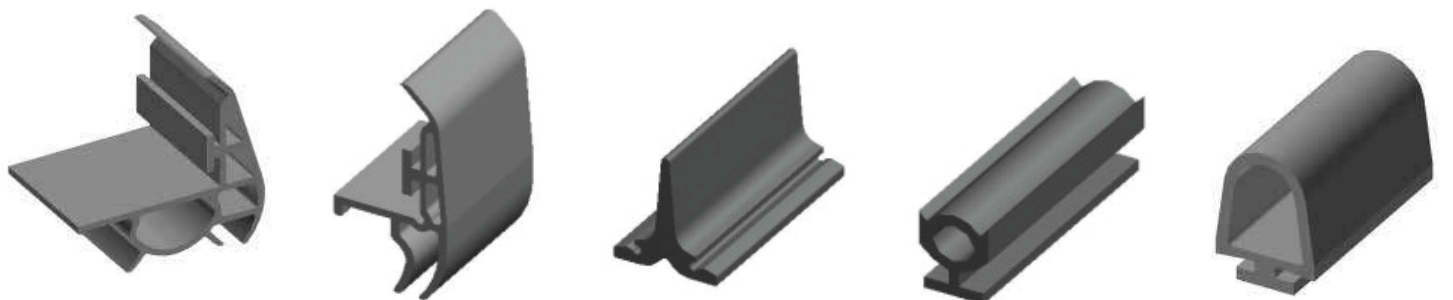

06F100022

06F100032

06F100031

06F100030

06F100001

# Dandoors & Fermod Accessories

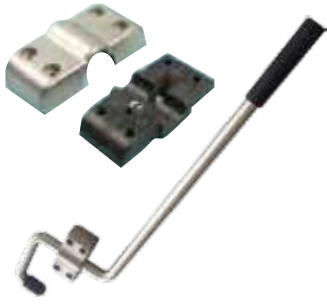

35-0229

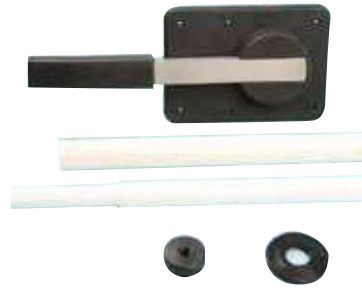

35-0223



30-3010



30-3050



30-1500 (64mm)  
30-1800 (80mm)



25-0031



25-1520



25-0010



25-0090



3530



55



2320



3530



921



4150-101



481



473



27



8511/3312



250/3362



4451/3352



3350/3362



2220



1832



2230

# PVC PROFILES & ACCESSORIES

For a Clean  
Environment...

High Quality PVC Profiles Extrusions & Fixing Accessories :

■ Cold Rooms

■ Freezers

■ Clean Rooms



### EX. 14 Large Corner Profiles :

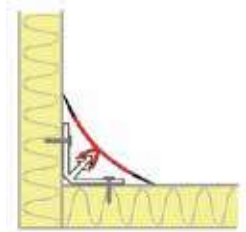

Large PVC Covings EX 14 are ideal for finishing cold- and clean rooms. Both sides have been fitted with soft edges for better sealing.

The large PVC covings are available in standard Colours:

9002, 9010, 9010N

Other colors such as 9005, 3020, 5010, 6018, 1021 and 9006 are available upon request.

### Accessories:



### EX. 28 Heavy Duty Backing Profiles :

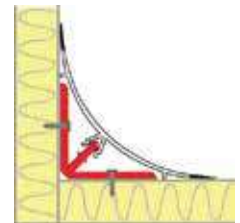

The EX28 Heavy Duty Backing Profiles has been especially developed to offer high durability and rigidity despite the low weight.

The profile is compatible with both the EX14 and the EX54 hygienic corner profiles and is easily fixed to the wall.

### EX. 40 Small Corner Profiles :

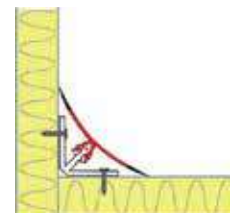

The Small PVC Covings are ideal for finishing cold- and clean rooms. Both sides have been fitted with soft edges for better sealing.

The small PVC Covings are available in standard Colors: 9002, 9010, 9010N

Other colors such as 9005, 3020, 5010, 6018, 1021 and 9006 are available upon request.

### EX. 41 Small L-Backing Profile :

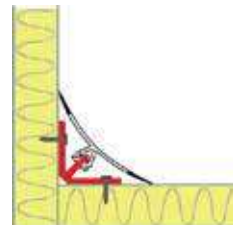

The EX41 Small L-backing Profile has been especially developed to offer durability and rigidity in a small form factor. The EX41 only measures 25x25 mm while maintaining compatibility with several hygienic profiles. The profile is compatible with the EX54, EX11 and EX14 profile and is easily fixed to the wall.

### EX. HOEKALU – Alum. Backing Profiles :

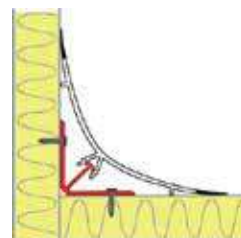
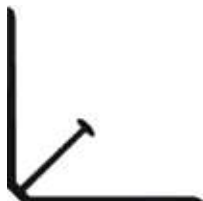

The HOEKALU Backing Profiles offers extreme rigidity and durability when you need it the most. The HOEKALU series are available in 3 different sizes offering full compatibility with our Hygienic Profiles.

- Hoekalu.30: 28x28mm L-backing Profile
- Hoekalu.35: 35x35mm L-backing Profile
- Hoekalu.40: 40x40mm L-backing Profile

### EX. 15 High End PVC Plinth

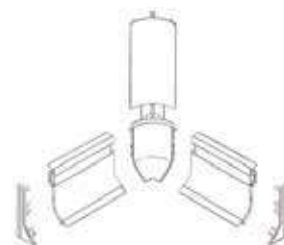

High End PVC Plinths are ideal for finishing cold- and clean rooms. Both sides have been fitted with soft edges for better sealing

The large PVC covings standard colours available in:  
9002, 9010, 9010N, 9006

EX15 Profiles include an invisible screw fixing feature, further improving hygiene and looks of the cold- / clean room.

### Accessories:



## Heavy Duty Bump Rail EX 81-82

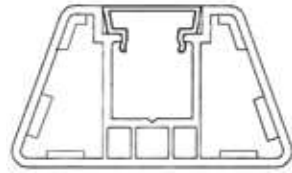

INJ 334



INJ 296

Heavy Duty Bump Rail is produced from very rigid PVC making it highly resistant to impacts.

EX 81-82 Bump Rails feature an invisible screw fixing due to the cosmetic stripe which is available in several colors.

The base is available in:

9002, 9010N, 9006

## Rounded U' Channels :



The Rounded U channels are convenient for food safe partitioning inside cold rooms and have a fast sealant option (if required).

All of our U' channels are fully compatible with EX.15 and EX.80 plinths.

U channels are available in 5 different sizes and 3 standard colors:

9002, 9010, 9010N

Sizes & references			
	Width	Height	Length
EX.04	60mm	45 mm	3 lm
EX.49	75 mm	45 mm	3 lm
EX.05	80 mm	45 mm	3 lm
EX.06	100 mm	45 mm	3 lm
EX.23	120 mm	45 mm	3 lm

## T Ceiling Suspension Profile : TST01



Hanger Bolt - A88



Available in Galvanized Steel and Aluminium with Fixing Accessories.

Size Available in : GI -130mm x 68mm x 4m long

Alum -84 x 64 x 6 m long

## Symmetric U Channels :

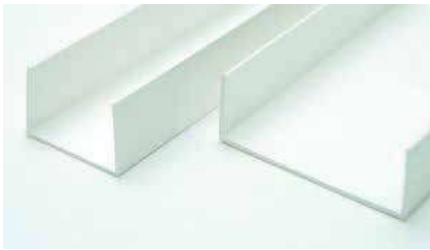

Symmetric U channels are multi-purpose, they can be used for door frame finish as well as industrial panel installations.

Several sizes are available (please refer to table below) and standard colors are:

9002, 9010N, Neutral white\*

\*slight variation may be noticed between production batches.

Sizes & references				
	Height	Width	Thickness	Length
EX.101	30 mm	30 mm	1,5 mm	4 lm
EX.102	30 mm	40 mm	1,5 mm	4 lm
EX.103	30 mm	50 mm	1,5 mm	4 lm
EX.104	30 mm	60 mm	1,5 mm	4 lm
EX.105	30 mm	75 mm	2 mm	4 lm
EX.106	30 mm	80 mm	2 mm	4 lm
EX.107	30 mm	100 mm	2 mm	4 lm
EX.108	30 mm	125 mm	2 mm	4 lm

# MAGNETIC STRIPS & DOOR GASKETS

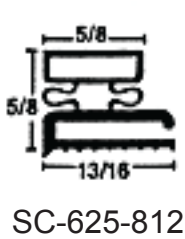
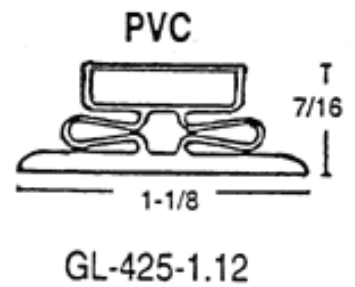
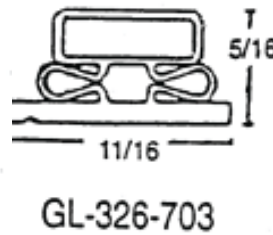
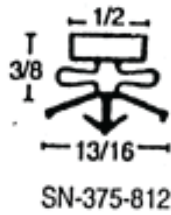
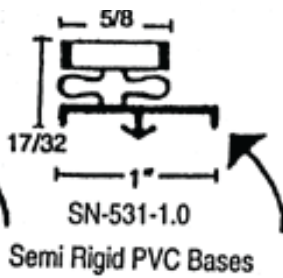
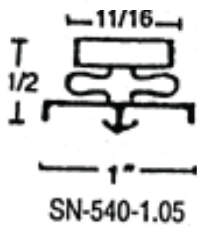
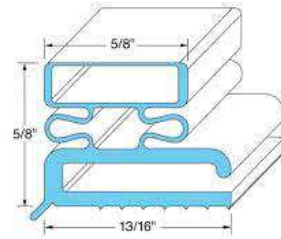
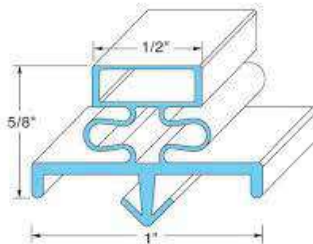
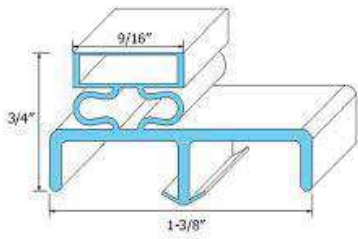
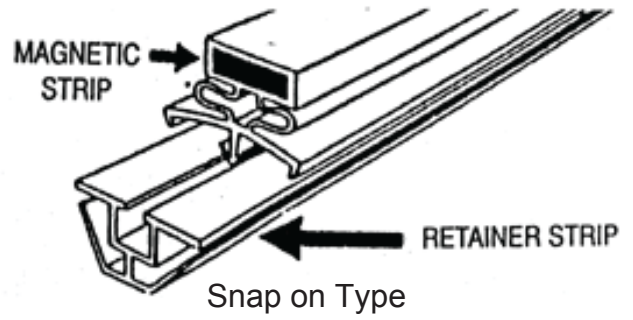
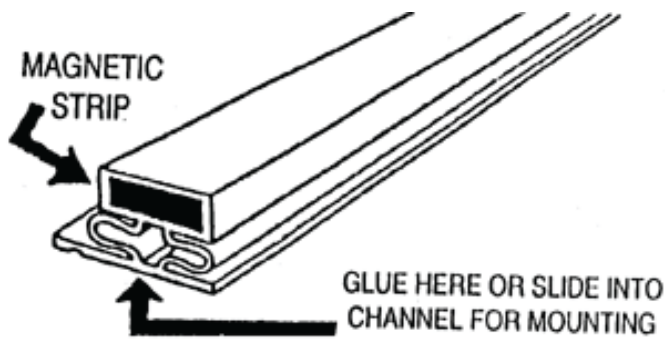

## Screw On Type Magnetic Gaskets

Colour: Grey & Black

Flexible PVC & TPE Gaskets with Magnetic Strip inserts provide energy efficient seal.

Temperature:

PVC : -20°F - +150°F

TPE : -60°F - +275°F

Standard colours include light grey, black & white

**Flexible Magnetic Strip:** Available from .30" - .120" Thick & 1/2" - 3" wide, Available in 200 ft Coils

**Leading Company within  
Electrical Under Floor Heating**



**Electric Floor Heating Cables  
Heater Mats  
Thermostats  
Accessories**



## FLOOR HEATING CABLES



### DEVI FAST

### SENSOR

### HEATER MAT

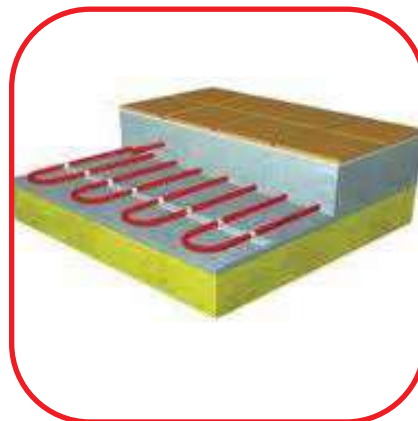

# INSULATED TRUCK BODY PARTS

Superior Quality Truck Body Components Available in SS & GI

- Container Locks
- Recessed Door Locks
- Rare Door Hinges
- Side Door Hinges
- Rubber Profiles
- Ceiling Lights



# Truck Door Hinges & Locks

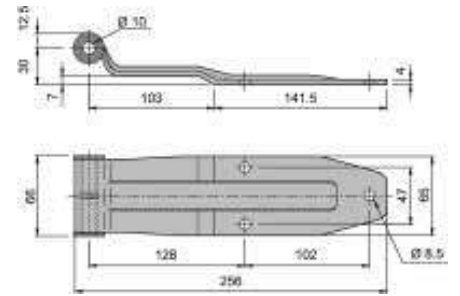
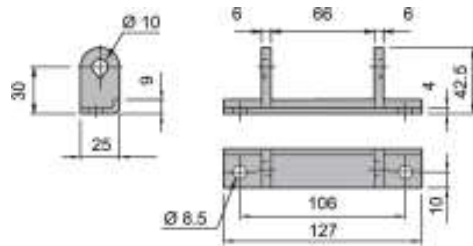

Part No - 070116351A & 0770322203A

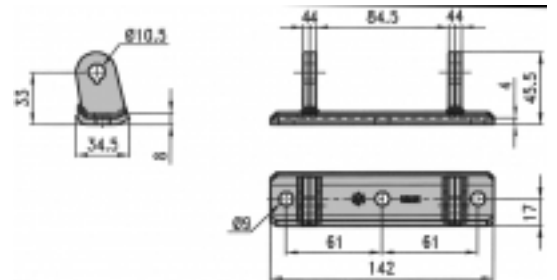
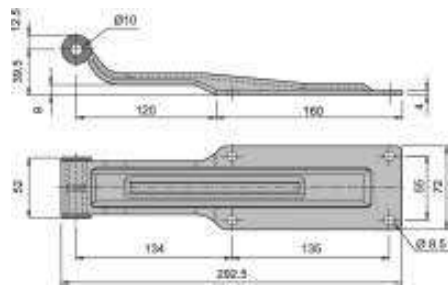

Part No - 070116966A & 070322204B

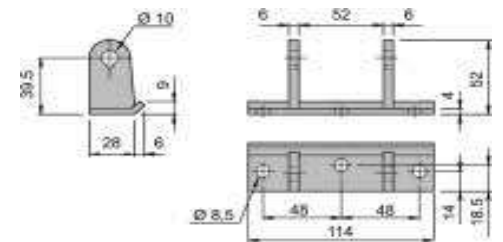
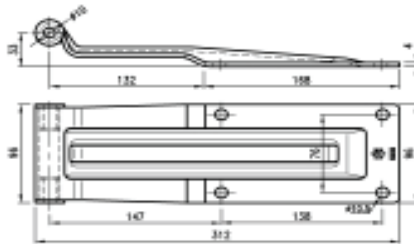

Part No - 070120776A & 070326343

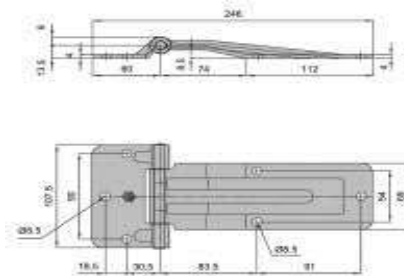

Part No - 070825004A

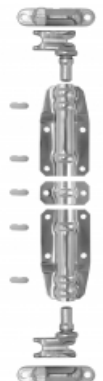

Part No - 071222167A

# Truck Body Parts & Gaskets

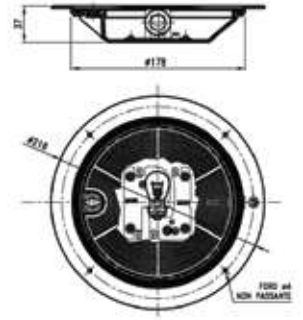

Part No - 072310945

Part No - 072322748

Part No - 038627014

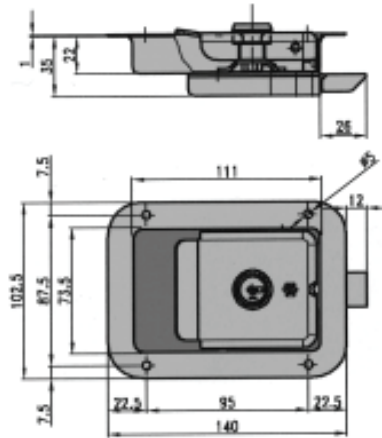

Part No - 030515673A

Part No - 071425950

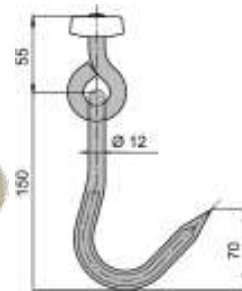
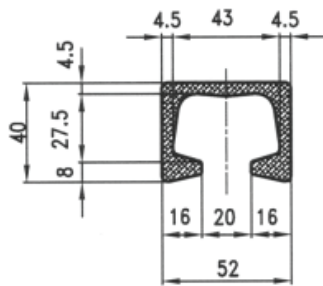
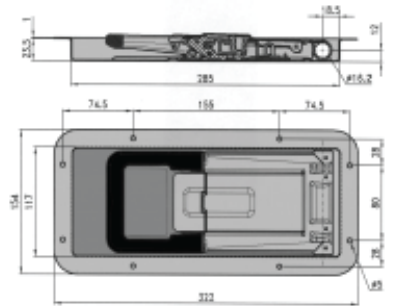

Part No - 072515899

Part No - 072520741A & 072520741B



035519095A

035521236A

072014003A

072023872

# PVC STRIP CURTAINS & SHEETS



**Leading Brand PVC Strip Curtains, Sheets & Fixing Accessories**

**From UK & FRANCE**

- **Environmental Friendly Products**
- **UV Stable**
- **Non-Toxic**
- **Flexible**
- **Complying with Food Industry Standards**
- **Made From Recyclable Compounds**



## Plain PVC Roll

Standard grade clear PVC is a high performance, flexible extrusion made specifically for strip curtain and impact door applications.

### Technical Specifications

Standard- Specification	Test Method	Typical value
Shore A Hardness	ASTM D-2240	80 °
Specific Gravity	ASTM D-792	1.23
Tensile Strength, psi	ASTM D-638	2600
Elongation %	ASTM D-638	360
100% Modulus, psi	ASTM D-638	1360

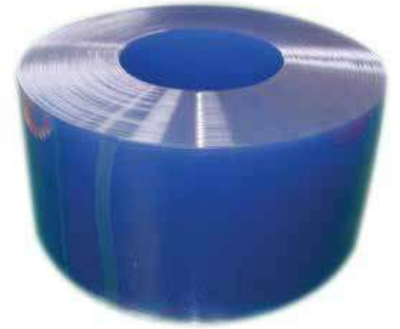

Polar- Specification	Test Method	Typical value
Shore A Hardness	ASTM D-2240	66°
Specific Gravity	ASTM D-792	1.18
Tensile Strength, psi	ASTM D-638	1800
Elongation %	ASTM D-638	435
100% Modulus, psi	ASTM D-638	700

### Product Properties

- Transparent with blue tint
- Working temperature range -15°C to + 40°C
- Hardness 80° Shore A
- Noise insulation > 35dB (Depending on thickness)

### Available sizes

100mm x 1.2mm	100mm x 2mm	100mm x 3mm	150mm x 2mm	150mm x 3mm
190mm x 2mm	200mm x 2mm	200mm x 3mm	200mm x 4mm	300mm x 2mm
300mm x 3mm	300mm x 4mm	300mm x 5mm	380mm x 2.5mm	380mm x 3mm
380mm x 4mm	400mm x 2mm	400mm x 2.5mm	400mm x 3mm	400mm x 4mm
400mm x 5mm				

## Ribbed PVC Roll

A high quality PVC extrusion available in both standard and polar grade material. Durable and long lasting, the material offers additional scratch and abrasion resistance in areas of heavy use.

Standard grade offers reduced friction when used in contact with cling film wrapped pallets. Polar grade offers reduced sticking of curtain blades where condensation occurs. Additionally both offer a better overall seal than smooth strip.

### Technical Specifications

Standard- Specification	Test Method	Typical value
Shore A Hardness	ASTM D-2240	80 °
Specific Gravity	ASTM D-792	1.23
Tensile Strength, psi	ASTM D-638	2600
Elongation %	ASTM D-638	360
100% Modulus, psi	ASTM D-638	1360



<b>Polar- Specification</b>	<b>Test Method</b>	<b>Typical value</b>
Shore A Hardness	ASTM D-2240	66°
Specific Gravity	ASTM D-792	1.18
Tensile Strength, psi	ASTM D-638	1800
Elongation %	ASTM D-638	435
100% Modulus, psi	ASTM D-638	700

### **Product Properties**

#### **Standard**

- Transparent with blue tint
- Working temperature range -15°C to + 40 °C
- Hardness 80° Shore A

#### **Polar**

- Transparent with blue tint
- Working temperature range -38°C to +25°C
- Hardness 66 ° Shore A

### **Available sizes**

200mm x 2mm      300mm x 2mm      300mm x 3mm      400mm x 4mm

## **Colored PVC Roll**

Available in standard and polar grades in smooth and ribbed profile. Used for defining doorway edges and access points. We have a standard range of red, blue, black, white and yellow.

\*Color match to RAL references subject to quantity.



### **Technical Specifications**

<b>Standard Specification</b>	<b>Test Method</b>	<b>Typical value</b>
Shore A Hardness	ASTM D-2240	80°
Specific Gravity A	STM D-792	1.23
Tensile Strength, psi	ASTM D-638	2600
Elongation %	ASTM D-638	360
100% Modulus, psi	ASTM D-638	1360

<b>Polar Specification</b>	<b>Test Method</b>	<b>Typical value</b>
Shore A Hardness	ASTM D-2240	66°
Specific Gravity	ASTM D-792	1.18
Tensile Strength, psi	ASTM D-638	1800
Elongation %	ASTM D-638	435
100% Modulus, psi	ASTM D-638	700

### **Product Properties**

#### **Standard**

- Red, Blue, Black, White or Yellow
- Working temperature range -15°C to +40°C
- Hardness 80° Shore A
- Noise insulation > 35dB (Depending on thickness)

#### **Polar**

- Red, Blue, Black, White or Yellow
- Working temperature range -38°C to +25°C
- Hardness 66° Shore A

### **Available sizes**

100mm x 2mm      200mm x 2mm      300mm x 2mm  
 300mm x 3mm      400mm x 3mm      400mm x 4mm

## Welding Grade PVC Roll

For welding applications and partial sight barriers. Available in bronze, green and red tints conforming to EN 1598.

### Technical Specifications

Specification	Test Method	Typical value
Shore A Hardness	ASTM D-2240	80°
Specific Gravity	ASTM D-792	1.23
Tensile Strength, psi	ASTM D-638	2600
Elongation %	ASTM D-638	360
100% Modulus, psi	ASTM D-638	1360



### Product Properties

- Red, green and bronze tints
- Working temperature range -15°C to + 52°C
- Hardness 80° Shore A

### Available sizes

200mm x 2mm      300mm x 2mm      300mm x 3mm

## PVC Sheet

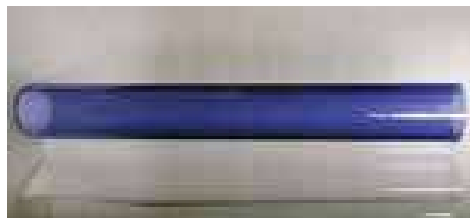

A range of smooth, standard and polar grade sheets available in 20m rolls from 500 to 2200 mm wide & 1 to 12 mm thick. Used for impact door panels, rapid roll doors and large dividing curtains

### Technical Specifications

Standard Specification	Test Method	Typical value
Shore A Hardness	ASTM D-2240	80°
Specific Gravity	ASTM D-792	1.23
Tensile Strength, psi	ASTM D-638	2600
Elongation %	ASTM D-638	360
100% Modulus, psi	ASTM D-638	1360

Polar Specification	Test Method	Typical value
Shore A Hardness	ASTM D-2240	66°
Specific Gravity	ASTM D-792	1.18
Tensile Strength, psi	ASTM D-638	1800
Elongation %	ASTM D-638	435
100% Modulus, psi	ASTM D-638	700

## Product Properties

### Standard

- Working temperature range -15C to + 40C
- Hardness 80° Shore A
- Noise insulation > 35dB (Depending on thickness)

### Polar

- Working temperature range -38°C to +25°C
- Hardness 66° Shore A

### Available sizes

500 mm to 2200 mm width & 1mm up to 12mm thickness

## Anti-Insect Active Strip

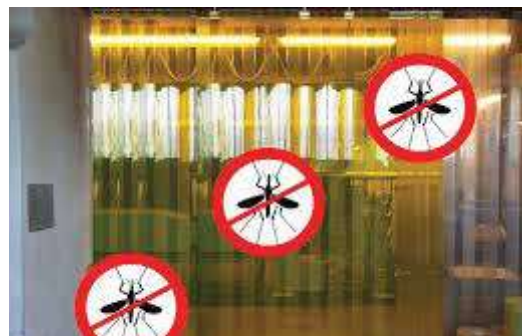

The first anti-insect active strip with citronella. The first soft PVC strip proven to deter insects. Protection against insects is a major concern in hot countries, particularly to protect food items. It protects effectively and economically.

**Now launch:** DOUBLE ACTIVE + PASSIVE PROTECTION ANTI-INSECT SOFT PVC STRIP.

**Active protection:** an agent containing citronella is incorporated in the compound.

**Passive protection:** the wavelength of the compound color lies beyond the one which the insect can no longer Distinguish colors.

This strip is the ecological and economic alternative to air curtains and UV lamps.

### Available sizes

200mm x 2mm

300mm x 3mm

### Also Available:

- Anti bacterial &
- Fire retardant strips.

## SS Hanging Rails & Plates

### SS Rails are available in

1.0 mtr & 2.0 mtr long

### SS Plates are available in

200 mm & 300 mm wide strips



# CLADDING, ROOFING & SANDWICH PANELS



**WALL, ROOF, TILE & DECKING SHEETS**

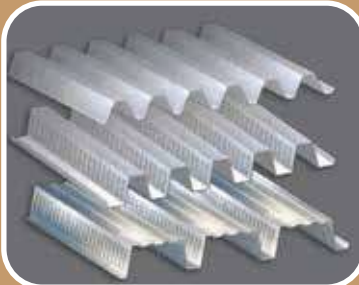
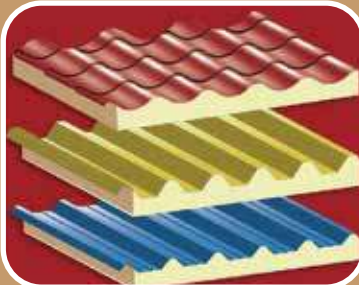
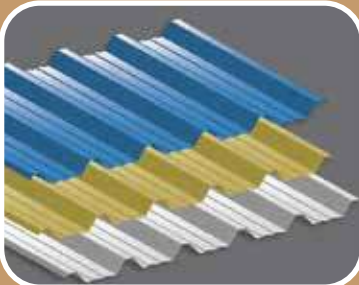

**FIXING ACCESSORIES**

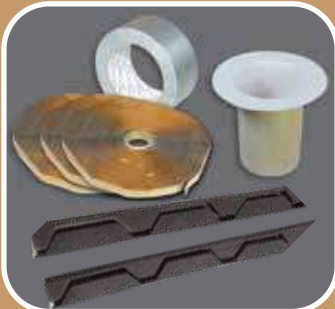

**Z & C PURLIN**

**SANDWICH PANELS**

**INSULATION MATERIAL**





- Dealers of Well Known & Reliable Brands.
- Service With No Compromize In Quality.



برد اتلانتا للتجارة ذ.م.م  
**BARAD ATLANTA** TRADING L.L.C.



*Contact Us :*

Post Box-61975, Industrial Area-11, (Near Bin Laden-New Signal), Sharjah, United Arab Emirates.  
Tel: +971 6 5443301, Fax: +971 6 5443302, Email: info@albaraduae.com, Web: albaraduae.com